



USER GUIDE

5.6.0 | July 2017 | 3725-49077-002A

Polycom[®] VVX[®] Business Media Phones for Skype for Business



Copyright© 2017, Polycom, Inc. All rights reserved. No part of this document may be reproduced, translated into another language or format, or transmitted in any form or by any means, electronic or mechanical, for any purpose, without the express written permission of Polycom, Inc.

6001 America Center Drive
San Jose, CA 95002
USA

Trademarks Polycom®, the Polycom logo and the names and marks associated with Polycom products are trademarks and/or service marks of Polycom, Inc. and are registered and/or common law marks in the United States and various other countries.



All other trademarks are property of their respective owners. No portion hereof may be reproduced or transmitted in any form or by any means, for any purpose other than the recipient's personal use, without the express written permission of Polycom.

Disclaimer While Polycom uses reasonable efforts to include accurate and up-to-date information in this document, Polycom makes no warranties or representations as to its accuracy. Polycom assumes no liability or responsibility for any typographical or other errors or omissions in the content of this document.

Limitation of Liability Polycom and/or its respective suppliers make no representations about the suitability of the information contained in this document for any purpose. Information is provided "as is" without warranty of any kind and is subject to change without notice. The entire risk arising out of its use remains with the recipient. In no event shall Polycom and/or its respective suppliers be liable for any direct, consequential, incidental, special, punitive or other damages whatsoever (including without limitation, damages for loss of business profits, business interruption, or loss of business information), even if Polycom has been advised of the possibility of such damages.

End User License Agreement BY USING THIS PRODUCT, YOU ARE AGREEING TO THE TERMS OF THE END USER LICENSE AGREEMENT (EULA) . IF YOU DO NOT AGREE TO THE TERMS OF THE EULA, DO NOT USE THE PRODUCT, AND YOU MAY RETURN IT IN THE ORIGINAL PACKAGING TO THE SELLER FROM WHOM YOU PURCHASED THE PRODUCT.

Patent Information The accompanying product may be protected by one or more U.S. and foreign patents and/or pending patent applications held by Polycom, Inc.

Open Source Software Used in this Product This product may contain open source software. You may receive the open source software from Polycom up to three (3) years after the distribution date of the applicable product or software at a charge not greater than the cost to Polycom of shipping or distributing the software to you. To receive software information, as well as the open source software code used in this product, contact Polycom by email at OpenSourceVideo@polycom.com (for video products) or OpenSourceVoice@polycom.com (for voice products).

Customer Feedback We are striving to improve our documentation quality and we appreciate your feedback. Email your opinions and comments to DocumentationFeedback@polycom.com.

Polycom Support Visit the [Polycom Support Center](#) for End User License Agreements, software downloads, product documents, product licenses, troubleshooting tips, service requests, and more.

Contents

| | |
|---|-----------|
| Before You Begin..... | 9 |
| Audience, Purpose, and Required Skills..... | 9 |
| Related Documentation..... | 9 |
| Get Help..... | 10 |
| Polycom Partner and Solution Resources..... | 10 |
| The Polycom Community..... | 10 |
| | |
| Getting Started with a VVX Business Media Phone..... | 11 |
| Overview of Phone Hardware and Keys..... | 11 |
| VVX 201 Hardware..... | 11 |
| VVX 300 Series Hardware..... | 13 |
| VVX 400 Series Hardware..... | 14 |
| VVX 500 Series and VVX 600 Series Hardware..... | 16 |
| Securing Your Phone with the Security Slot..... | 17 |
| Navigating VVX Business Media Phone..... | 18 |
| Accessing Screens on VVX Business Media Phone..... | 18 |
| Icons and Status Indicators..... | 21 |
| Entering Information in Data Fields..... | 26 |
| Entering Information Using the Dial Pad..... | 26 |
| Enter Information Using the Onscreen Keyboard..... | 27 |
| Entering Chinese Characters with PinYin..... | 28 |
| | |
| Logging Into and Locking Your Phone..... | 30 |
| Signing into Skype for Business..... | 30 |
| Sign In Using Your Skype for Business User Credentials..... | 30 |
| Sign Into Skype for Business on Your Computer Using BToE..... | 30 |
| Sign In Using Your Skype for Business PIN Authentication..... | 31 |
| Sign Into Skype for Business Using Web Sign In..... | 31 |
| Set the Time and Date Format..... | 31 |
| Sign Out of Skype for Business..... | 32 |
| Locking Your Phone..... | 32 |
| Set a Lock Code..... | 32 |
| Lock Your Phone..... | 33 |
| Unlock the Phone..... | 33 |
| Change Your Lock Code..... | 33 |
| Reset Your Lock Code..... | 34 |
| Disable Device Lock..... | 34 |

| | |
|--|-----------|
| Audio Calls..... | 35 |
| Placing and Answering Audio Calls..... | 35 |
| Placing Audio Calls..... | 35 |
| Redial a Number..... | 39 |
| Answering Audio Calls..... | 40 |
| Switch among the Handset, Headset, and Speakerphone..... | 42 |
| Mute and Unmute Audio..... | 42 |
| Holding and Resuming Calls..... | 43 |
| Hold a Call..... | 43 |
| Resume a Call..... | 43 |
| Resume a Call on a VVX Expansion Module..... | 43 |
| End an Active Audio Call..... | 43 |
| End a Held Call..... | 43 |
| Transferring Calls..... | 44 |
| Choose a Default Transfer Type..... | 44 |
| Transfer a Call..... | 44 |
| Cancel a Transfer..... | 45 |
| Parking and Retrieving Calls on the Skype for Business Server..... | 45 |
| Park Skype for Business Calls..... | 45 |
| Retrieving Parked Skype for Business Calls..... | 46 |
| Managing Calls..... | 46 |
| Display Calls from the Lines Screen..... | 47 |
| Display Calls from the Calls Screen..... | 47 |
| Manage a Call from the Calls Screen..... | 47 |
| Ignoring or Rejecting Incoming Calls..... | 47 |
| Ignore or Silence an Incoming Call..... | 48 |
| Reject Incoming Calls..... | 48 |
| Reject Calls from a Contact..... | 48 |
| Rejecting Calls with Do Not Disturb..... | 48 |
| Redirecting Incoming Calls..... | 50 |
| Forwarding Incoming Skype for Business Calls..... | 50 |
| Divert Calls to a Contact..... | 51 |
| | |
| Conference Calls..... | 52 |
| Tips for Conference Calls..... | 52 |
| Initiating a Skype for Business Conference Call..... | 52 |
| Initiate a Skype for Business Conference..... | 52 |
| Initiate a Conference Call during a Skype for Business Call..... | 53 |
| Initiating a Group Conference Call..... | 53 |
| Initiate a Group Conference Call..... | 53 |

| | |
|---|-----------|
| Initiate a Group Conference Call with a Distribution List..... | 53 |
| Add Contacts to a Skype for Business Conference Call..... | 54 |
| Send Contacts Active Conference Information..... | 54 |
| Viewing a List of Skype for Business Conference Participants..... | 54 |
| Exit the Roster..... | 55 |
| Return to the Roster..... | 55 |
| Managing Skype for Business Conference Participants..... | 55 |
| Muting Conference Participants..... | 56 |
| Demote or Promote Conference Participants..... | 56 |
| Enable and Disable Conference Announcements..... | 57 |
| Remove Conference Participants..... | 57 |
| Lock and Unlock a Conference Call..... | 57 |
| Admit or Deny Participants to a Locked Conference Call..... | 57 |
| Shared Lines..... | 59 |
| Shared Line Limitations..... | 59 |
| Missed and Received Calls on Shared Lines..... | 59 |
| Hold a Call Privately on a Shared Line..... | 59 |
| Shared Line Appearance for Skype for Business..... | 60 |
| Shared Line Appearance Limitations..... | 60 |
| Answering SLA Calls..... | 60 |
| Resume Held SLA Calls..... | 61 |
| Boss-Admin for Skype for Business..... | 61 |
| Assign Delegates..... | 61 |
| View the Delegates Group..... | 62 |
| View the Boss Group..... | 62 |
| Set a Ringtone for Boss Calls..... | 63 |
| Edit the Delegates Group..... | 63 |
| Managing Calls on the Boss's Line..... | 63 |
| Join Conference Calls for a Boss..... | 66 |
| Recording Audio Calls..... | 67 |
| Guidelines when Recording Calls..... | 67 |
| Record a Call..... | 68 |
| Manage a Call while Recording..... | 68 |
| Pause a Recording..... | 68 |
| Resume a Recording..... | 68 |
| Stop Recording..... | 68 |
| Record a Conference Call..... | 69 |
| Browse Recorded Calls..... | 69 |
| Play a Recorded Call..... | 69 |

| | |
|--|-----------|
| Pause and Resume Played Recordings..... | 70 |
| Stop Playing a Recording..... | 70 |
| Rename a Recording..... | 70 |
| Delete a Recording..... | 70 |
| Call Lists, Distribution Lists, and Directories..... | 72 |
| Recent Calls..... | 72 |
| View Recent Calls..... | 72 |
| Sort Recent Call Entries..... | 73 |
| Sort Entries by Call Type..... | 73 |
| Edit a Recent Call Entry..... | 73 |
| Delete a Recent Call Entry..... | 73 |
| Save a Recent Call Entry..... | 74 |
| View Call Details..... | 74 |
| Contact Directory..... | 74 |
| Search for a Contact in the Contact Directory..... | 74 |
| Add a Contact to the Contact Directory..... | 75 |
| View Contact Information..... | 75 |
| Update a Contact's Information..... | 75 |
| Delete a Contact from the Contact Directory..... | 76 |
| Corporate Directory..... | 76 |
| Searching the Corporate Directory..... | 76 |
| Add Corporate Directory Contacts to the Contact Directory..... | 77 |
| Searching the Skype for Business and Outlook Directories..... | 78 |
| Search the Skype for Business Directory..... | 78 |
| Saving Contacts from the Skype for Business Directory..... | 78 |
| Search the Outlook Directory..... | 79 |
| Save Outlook Contacts to the Contact Directory..... | 79 |
| Managing Skype for Business Distribution Lists..... | 79 |
| Maximum Number of Distribution List Members..... | 79 |
| Search for Skype for Business Distribution Lists..... | 80 |
| Save a Distribution List to the Contacts List..... | 80 |
| View Contact Information for a Distribution List | 81 |
| View Contact Information for a Member of a Distribution List | 81 |
| Delete a Distribution List | 81 |
| Favorites and Contact Lists..... | 82 |
| Managing Favorites..... | 82 |
| Add Favorites..... | 82 |
| Viewing Favorites..... | 82 |
| Reorder Favorites..... | 83 |

| | |
|--|-----------|
| Delete Favorites..... | 83 |
| Skype for Business Contacts..... | 84 |
| Unified Contact Store..... | 84 |
| Add a Contact to Your Microsoft Skype for Business Contact List..... | 84 |
| View Skype for Business Favorites and Groups..... | 85 |
| Assign Skype for Business Contacts to Line Keys..... | 85 |
| Skype for Business Contacts' Presence Information..... | 86 |
| View the Skype for Business Contacts' Information..... | 88 |
| Change the Privacy Relationship for a Contact..... | 89 |
| Accessing, Sending, and Broadcasting Messages..... | 90 |
| Access Skype for Business Voicemail Messages..... | 90 |
| Managing Skype for Business Voicemail Messages..... | 90 |
| Call a Contact from Voicemail..... | 90 |
| Delete Voicemail Messages..... | 90 |
| Mark Message as Read..... | 91 |
| Instant Messaging..... | 91 |
| Send Instant Messages..... | 91 |
| Read Instant Messages..... | 91 |
| Reply to Instant Messages..... | 92 |
| Delete Instant Messages..... | 92 |
| Broadcasting Messages with Group Paging..... | 92 |
| Send a Group Page..... | 92 |
| Receiving Pages..... | 93 |
| Group Paging Settings..... | 94 |
| Broadcasting Messages with Push to Talk..... | 95 |
| Send a PTT Broadcast..... | 95 |
| Receiving PTT Broadcasts..... | 96 |
| Reply to PTT Broadcasts..... | 97 |
| End PTT Broadcasts..... | 97 |
| Push-To-Talk Settings..... | 97 |
| Phone Applications..... | 99 |
| Using the Calendar..... | 99 |
| Open the Calendar..... | 99 |
| Navigate to Other Views..... | 99 |
| Display Meeting View..... | 100 |
| Meeting Reminders..... | 100 |
| Joining Calendar Meetings..... | 101 |
| Navigating the Browsers..... | 102 |
| View the Idle Browser..... | 102 |

| | |
|---|------------|
| Open the Web Browser..... | 103 |
| VVX Business Media Phone Settings..... | 104 |
| Password Required to Access Basic Settings..... | 104 |
| Set the Language..... | 104 |
| Change the Time and Date Format..... | 105 |
| Disable the Time and Date Display..... | 105 |
| Backlight Intensity and Timeout..... | 105 |
| Set the Backlight Intensity..... | 106 |
| Set the Backlight Timeout..... | 106 |
| Changing Your Background..... | 106 |
| Change the Background Picture..... | 106 |
| Adding Personal Photos as Your Background..... | 107 |
| Reset Your Background..... | 108 |
| Customizing Line Keys..... | 108 |
| Customize the Columns on the Lines Screen..... | 109 |
| Enable Transparent Line Keys..... | 109 |
| Show Only Your Line Registration..... | 110 |
| Enable Line Key Customization..... | 110 |
| Insert an Empty Line Key..... | 110 |
| Clear a Line Key..... | 111 |
| Delete a Line Key..... | 111 |
| Reset Customized Line Keys..... | 111 |
| Screen Savers..... | 111 |
| Enable Screen Savers..... | 112 |
| Use Personal Photos as Screen Savers..... | 112 |
| Disable the Screen Saver..... | 113 |
| Use Your Phone as a Digital Picture Frame..... | 113 |
| Picture Frame Icons..... | 114 |
| Power-Saving Mode..... | 115 |
| Change Your Office Hours..... | 115 |
| Change Timeouts..... | 115 |
| Changing Audio Settings..... | 116 |
| Change Incoming Call Notifications..... | 116 |
| Set a Ringtone for Incoming Calls..... | 116 |
| Set a Ringtone for Individual Contacts..... | 116 |
| Change the Volume..... | 117 |
| Update Your Skype for Business Presence..... | 117 |
| Adding a Profile Photo to Display on the Lock Screen..... | 117 |
| Phone Accessories and Computer Applications..... | 118 |

| | |
|---|------------|
| Using a Headset with Your Phone..... | 118 |
| Connecting a Headset..... | 118 |
| Use Your Headset for All Calls..... | 119 |
| Reactivate Headset Memory Mode..... | 119 |
| Using Electronic Hookswitch..... | 119 |
| Disconnect Your Headset..... | 121 |
| Using Bluetooth Headsets with VVX 600 Phones..... | 121 |
| Controlling Your Phone with Polycom Desktop Connector..... | 123 |
| Setting Up and Enabling the Polycom Desktop Connector..... | 123 |
| Using the Polycom Desktop Connector..... | 126 |
| Connecting a Netgear Wi-Fi Adapter to Your Phone..... | 129 |
| Connect the Wi-Fi Adapter..... | 129 |
| Connecting Polycom VVX Expansion Modules to Your Phone..... | 130 |
| VVX Color Expansion Module Hardware Features..... | 130 |
| Connect VVX Expansion Modules..... | 132 |
| Connect Additional Expansion Modules..... | 132 |
| Assigning Contacts and Favorites to VVX Expansion Modules..... | 132 |
| Navigate VVX Color Expansion Module Paging..... | 134 |
| Changing the Backlight Intensity on VVX Expansion Modules..... | 136 |
| Connecting to Skype for Business on Your Phone using Better Together over Ethernet..... | 136 |
| Installing the Polycom Better Together over Ethernet Connector..... | 136 |
| Pairing Your Phone with Your Computer..... | 138 |
| Set Your Phone as Your Primary Audio Device..... | 141 |
| Use BToE to Open the Web Configuration Utility..... | 141 |
| Using BToE to Lock and Unlock Your Phone..... | 142 |
| Using BToE to Manage Calls on Your Phone and Skype for Business Client..... | 142 |
| Disable BToE on Your Phone..... | 143 |
| Stop BToE on Your Computer..... | 144 |
| Uninstall the Polycom BToE Connector..... | 144 |
| Accessibility Features | 145 |
| Features for Hearing-Impaired Users..... | 145 |
| Features for Mobility-Impaired Users..... | 146 |
| Features for Vision-Impaired and Blind Users..... | 147 |
| Maintaining VVX Business Media Phone..... | 148 |
| Investigate Warnings..... | 148 |
| Remove Warnings..... | 148 |
| Restart VVX Business Media Phone..... | 149 |
| Update the Configuration for VVX Business Media Phone..... | 149 |

| | |
|---|------------|
| Test the Hardware..... | 149 |
| Clean the Touchscreen..... | 150 |
| View Software Details..... | 150 |
| Updating Your Skype for Business Phone Software..... | 151 |
| View Software Update Information..... | 151 |
| Update Your Skype for Business Phone Software..... | 151 |
| Update Skype for Business Software Later..... | 151 |
| Troubleshooting..... | 152 |
| Speakerphone..... | 152 |
| USB Port..... | 152 |
| Check the Status of the Calendar..... | 152 |
| Polycom Desktop Connector..... | 153 |
| Troubleshoot Audio and Echo Issues..... | 154 |
| Bluetooth Headset..... | 154 |
| Recording Issues and Solutions..... | 154 |
| Better Together over Ethernet..... | 155 |
| Troubleshoot Polycom BToE Connector Installation..... | 155 |
| Troubleshoot Polycom BToE Connector Start Issues..... | 155 |
| Troubleshoot Pairing..... | 156 |
| Login Credentials..... | 156 |
| Set Log Levels..... | 157 |
| Send Log Files to the Skype for Business Server..... | 157 |
| Send Log Files to the Skype for Business Server using the Web Configuration Utility..... | 157 |

Before You Begin

Topics:

- [Audience, Purpose, and Required Skills](#)
- [Related Documentation](#)
- [Get Help](#)

This Polycom VVX Business Media Phones for Skype for Business User Guide contains overview information for navigating and performing tasks on Polycom® VVX® Business Media Phones.

This user guide contains information for the following Polycom® VVX® products:

- VVX 201 business media phones
- VVX 300, 301, 310, and 311 business media phones
- VVX 400, 401, 410, and 411 business media phones
- VVX 500 and 501 business media phones
- VVX 600 and 601 business media phones
- VVX Expansion Modules

Audience, Purpose, and Required Skills

This guide is intended for beginning users, as well as intermediate and advanced users, who want to learn more about the features available on a VVX Business Media Phone.

Related Documentation

For additional information about Polycom VVX products, view the following support pages:

- [Polycom VVX 201](#)
- [Polycom VVX 300 and 310](#)
- [Polycom VVX 301 and 311](#)
- [Polycom VVX 400 and 410](#)
- [Polycom VVX 401 and 411](#)
- [Polycom VVX 500](#)
- [Polycom VVX 501](#)
- [Polycom VVX 600](#)
- [Polycom VVX 601](#)
- [Polycom VVX Expansion Modules](#)

You can view the following types of documents on each product page:

- Quick Tips—A quick reference on how to use the phone's most basic features.

- **Quick Start Guide**—This guide describes the contents of your package, how to assemble the phone or accessory, and how to connect the phone to the network. The quick start guide is included in your phone package.
- **Wallmount Instructions**—This document provides detailed instructions for mounting your phone on the wall. To install your phone on the wall, you need the optional wallmount package, which includes the wallmount instructions.
- **Administrator Guide**—This guide provides detailed information about setting up your network and configuring features.
- **Regulatory Notice**—This guide provides information for all regulatory and safety guidance.

You can also view Feature Descriptions and Technical Notifications on the [Polycom Voice Support](#) page. These documents describe workarounds to existing issues and provide expanded descriptions and examples for phone settings and features. You can find these documents on the [Polycom Profiled UC Software Features](#) and [Polycom Engineering Advisories and Technical Notifications](#) support pages.

Get Help

For more information about installing, configuring, and administering Polycom products, refer to **Documents and Downloads** at [Polycom Support](#).

Polycom Partner and Solution Resources

To find all Polycom partner solutions, see [Strategic Global Partner Solutions](#).

Polycom Implementation and Maintenance services provide support for Polycom solution components only. Additional services for supported third-party Unified Communications (UC) environments integrated with Polycom solutions are available from Polycom Global Services and its certified Partners. These additional services help customers successfully design, deploy, optimize and manage Polycom visual communications within their UC environments.

Professional Services for Microsoft Integration is mandatory for Microsoft Office Communications Server, Microsoft Lync Server 2013, Skype for Business Server 2015, or Office 365 integrations. For additional information and details, refer to http://www.polycom.com/services/professional_services/index.html or contact your local Polycom representative.

The Polycom Community

The [Polycom Community](#) gives you access to the latest developer and support information, and the community enables you to participate in discussion forums to share ideas and solve problems with your colleagues. To register with the Polycom Community, simply create a Polycom online account. When logged in, you can access Polycom support personnel and participate in developer and support forums to find the latest information on hardware, software, and partner solutions topics.

Getting Started with a VVX Business Media Phone

Topics:

- [Overview of Phone Hardware and Keys](#)
- [Navigating VVX Business Media Phone](#)
- [Entering Information in Data Fields](#)

Before you use the phone, take a few moments to familiarize yourself with its features and user interface.

The terms “the phone” and “your phone” refer to any of the business media phones. Unless specifically noted in this guide, especially with regard to phone graphics, all VVX business media phones operate in similar ways.

Note: As you read this guide, keep in mind that certain features are configurable by your system administrator or determined by your network environment. As a result, some features may not be enabled or may operate differently on your device. Additionally, the examples and graphics in this guide may not directly reflect what is displayed or is available on your device screen.

Overview of Phone Hardware and Keys

Use the following figures and tables to understand your VVX phone's hardware features. For more information about attaching phone hardware, including how to connect your phone to the network, see the *Quick Start Guide* for your phone available on your phone's support page on [Polycom Voice Support](#).

Related Links

[Use Your Phone as a Digital Picture Frame](#) on page 113

[Use Personal Photos as Screen Savers](#) on page 112

VVX 201 Hardware

The following figure displays the hardware features on the VVX 201 business media phones. The table lists each feature numbered in the figure.

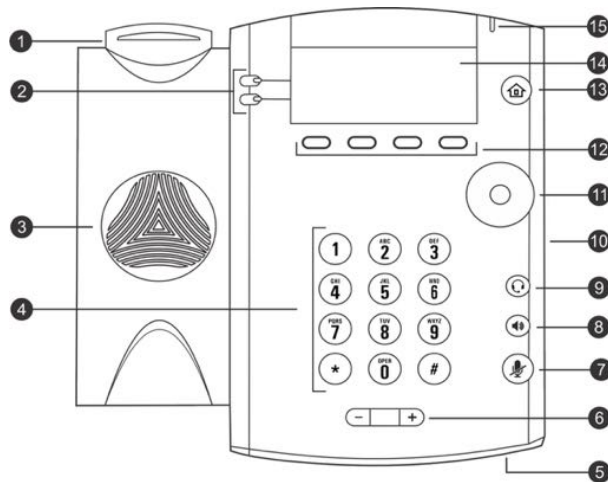
VVX 201 hardware features**VVX 201 Hardware Feature Descriptions**

| Reference Number | Feature | Feature Description |
|------------------|------------------------------|---|
| 1 | Hookswitch | Holds the handset and end calls. |
| 2 | Line keys | Enable you to select a phone line, view calls on a line, or quickly call a favorite contact. |
| 3 | Speaker | Provides ringer and speakerphone audio output. |
| 4 | Dialpad keys | Enable you to enter numbers, letters, and special characters. You can also use the dialpad keys to select menu items that have index numbers. |
| 5 | Microphone | Transmits audio to other phones. |
| 6 | Volume keys | Adjust the volume of the handset, headset, speaker, and ringer. |
| 7 | Mute key | Mutes local audio during calls and conferences. |
| 8 | Speakerphone key | Enables you to place and receive calls using the speakerphone. |
| 9 | Headset key | Enables you to place and receive calls through a headset. |
| 10 | Security slot (on side) | Enables you to attach a universal security cable lock to your phone so you can secure it to a desktop. |
| 11 | Navigation keys / Select key | Scrolls through information or options displayed on the phone's screen. Selects a field of displayed data. |

| Reference Number | Feature | Feature Description |
|------------------|---------------------------|--|
| 12 | Soft keys | Enable you to select context sensitive keys that display along the bottom of the screen. |
| 13 | Home key | Displays the Home screen from other screens, and displays the Lines and Calls screen from the Home screen. |
| 14 | Screen | Shows a 2.5-inch (6.35 cm) diagonal screen with a backlight that enables you to view menus and data. |
| 15 | Message Waiting Indicator | Flashes red to indicate when you have new messages. |

VVX 300 Series Hardware

The following figure displays the hardware features on the VVX 300, 301, 310, and 311 business media phones. The table lists each feature numbered in the figure.

VVX 300 series hardware features

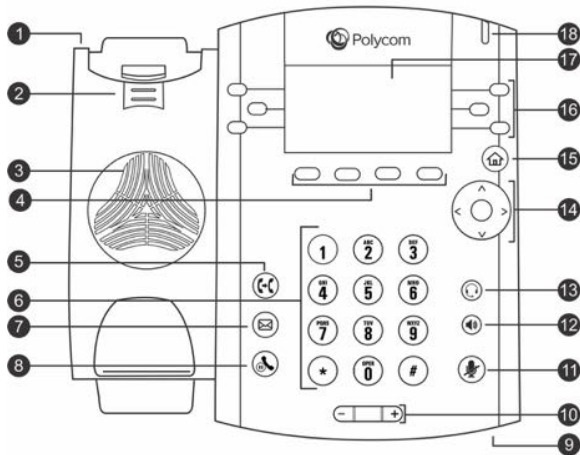

VVX 300 Series Hardware Feature Descriptions

| Reference Number | Feature | Feature Description |
|------------------|------------------------|--|
| 1 | Security slot (on top) | Enables you to attach a universal security cable lock to your phone so you can secure it to a desktop. |
| 2 | Reversible tab | Secures the handset in the cradle when your phone stand is positioned at a high angle. To secure the handset, remove the tab, reverse it so the protrusion points up, and re-insert it. Position the handset so the protrusion on the tab fits into the slot on the handset. |
| 3 | Speaker | Provides ringer and speakerphone audio output. |

| | | |
|----|-------------------------------|---|
| 4 | Soft keys | Enable you to select context sensitive keys that display along the bottom of the screen. |
| 5 | Transfer key | Transfers an active call to a contact. |
| 6 | Dialpad keys | Enable you to enter numbers, letters, and special characters. You can also use the dialpad keys to select menu items that have index numbers. |
| 7 | Messages key | Enables you to access and manage instant and voice messages. |
| 8 | Hold key | Holds an active call or resumes a held call. |
| 9 | Microphone | Transmits audio to other phones. |
| 10 | Volume keys | Adjust the volume of the handset, headset, speaker, and ringer. |
| 11 | Mute key | Mutes local audio during calls and conferences. The key glows red when activated. |
| 12 | Speakerphone key | Enables you to place and receive calls using the speakerphone. The key glows green when activated. |
| 13 | Headset key | Enables you to place and receive calls through a headset. The key glows green when an analog headset is activated, and blue when a USB or Bluetooth headset is activated. |
| 14 | Navigation key/ Select key | Scrolls through information or options displayed on the phone's screen. Selects a field of displayed data. |
| 15 | Home key | Displays the Home screen from other screens, and displays the Lines and Calls screen from the Home screen. |
| 16 | Line keys | Enable you to select a phone line, view calls on a line, or quickly call a favorite contact. |
| 17 | Screen | Shows a 3.2-inch (8.3 cm) diagonal screen with a backlight that enables you to view menus and data. |
| 18 | Message Waiting Indicator | Flashes red to indicate when you have new messages. |

VVX 400 Series Hardware

The following figure displays the hardware features on the VVX 400, 401, 410, and 411 business media phones. The table lists each feature numbered in the figure.

VVX 400 series hardware features

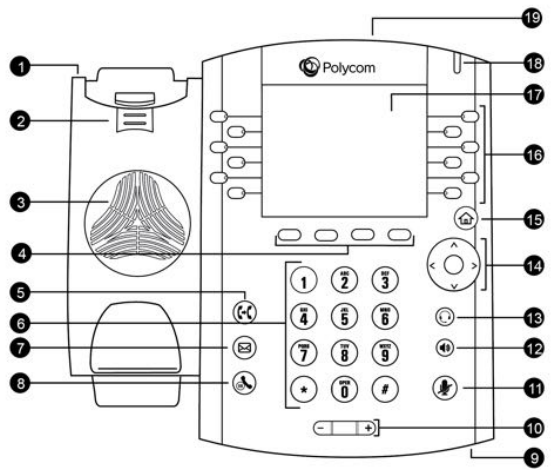

VVX 400 Series Hardware Feature Descriptions

| Reference Number | Feature | Feature Description |
|------------------|------------------------|--|
| 1 | Security slot (on top) | Enables you to attach a universal security cable lock to your phone so you can secure it to a desktop. |
| 2 | Reversible tab | Secures the handset in the cradle when your phone stand is positioned at a high angle. To secure the handset, remove the tab, reverse it so the protrusion points up, and re-insert it. Position the handset so the protrusion on the tab fits into the slot on the handset. |
| 3 | Speaker | Provides ringer and speakerphone audio output. |
| 4 | Soft keys | Enable you to select context sensitive keys that display along the bottom of the screen. |
| 5 | Transfer key | Transfers an active call to a contact. |
| 6 | Dialpad keys | Enable you to enter numbers, letters, and special characters. You can also use the dialpad keys to select menu items that have index numbers. |
| 7 | Messages key | Enables you to access and manage instant and voice messages. |
| 8 | Hold key | Holds an active call or resumes a held call. |
| 9 | Microphone | Transmits audio to other phones. |
| 10 | Volume keys | Adjust the volume of the handset, headset, speaker, and ringer. |
| 11 | Mute key | Mutes local audio during calls and conferences. The key glows red when activated. |

| | | |
|----|-------------------------------|---|
| 12 | Speakerphone key | Enables you to place and receive calls using the speakerphone. The key glows green when activated. |
| 13 | Headset key | Enables you to place and receive calls through a headset. The key glows green when an analog headset is activated, and blue when a USB or Bluetooth headset is activated. |
| 14 | Navigation key/ Select key | Scrolls through information or options displayed on the phone's screen. Selects a field of displayed data. |
| 15 | Home key | Displays the Home screen from other screens, and displays the Lines and Calls screens from the Home screen. |
| 16 | Line keys | Enable you to select a phone line, view calls on a line, or quickly call a favorite contact. |
| 17 | Screen | Shows a 3.5-inch (8.89 cm) diagonal screen with a backlight that enables you to view menus and data. |
| 18 | Message Waiting Indicator | Flashes red to indicate when you have new messages. |
| 19 | USB Port | Enables you to attach a USB flash drive or USB headset (VVX 411 only). |

VVX 500 Series and VVX 600 Series Hardware

The following figure displays the hardware features on the VVX 500, 501, 600, and 601 business media phones. The table lists each feature numbered in the figure.

VVX 500 series and VVX 600 series hardware features

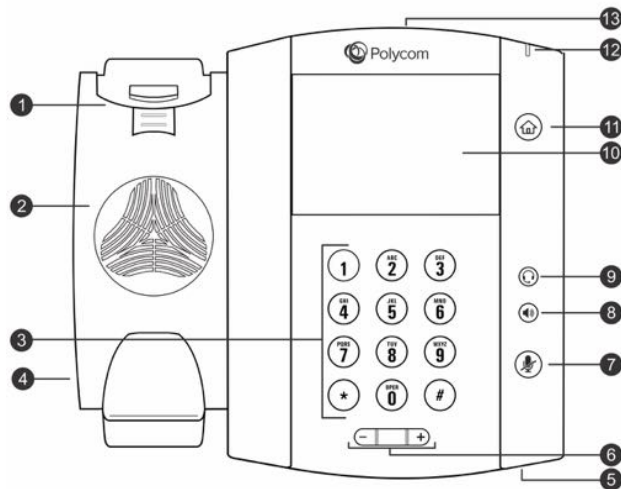

VVX 500 Series and 600 Series Hardware Feature Descriptions

| Reference Number | Feature | Feature Description |
|------------------|---------------------------|--|
| 1 | Reversible tab | Secures the handset in the cradle when your phone stand is positioned at a high angle. To secure the handset, remove the tab, reverse it so the protrusion points up, and re-insert it. Position the handset so the protrusion on the tab fits into the slot on the handset. |
| 2 | Speaker | Provides ringer and speakerphone audio output. |
| 3 | Dialpad keys | Enable you to enter numbers, letters, and special characters. You can also use the dialpad keys to select menu items that have index numbers. |
| 4 | Security slot (on side) | Enables you to attach a universal security cable lock to your phone so you can secure it to a desktop. |
| 5 | Microphone | Transmits audio to other phones. |
| 6 | Volume keys | Adjust the volume of the handset, headset, speaker, and ringer. |
| 7 | Mute key | Mutes local audio during calls and conferences. The key glows red when activated. |
| 8 | Speakerphone key | Enables you to place and receive calls using the speakerphone. The key glows green when activated. |
| 9 | Headset key | Enables you to place and receive calls through a headset. The key glows green when an analog headset is activated, and blue when a USB or Bluetooth headset is activated. |
| 10 | Touchscreen | Enables you to select items and navigate menus on the touch-sensitive screen. Tap the screen to select and highlight screen items. To scroll, touch the screen, and swipe your finger up, down, right, or left. |
| 11 | Home key | Displays the Home screen from other screens, and displays the Lines and Calls screens from the Home screen. |
| 12 | Message Waiting Indicator | Flashes red to indicate when you have new messages. |
| 13 | USB port | Enables you to attach a USB flash drive or a USB headset. |

Securing Your Phone with the Security Slot

The security slot is located on the top, left, or right side of the phone and is indicated by a padlock  symbol. See the hardware figure for your phone for the location of the security slot.

By fastening one end of a universal security cable to a stationary object such as a desk or table, and the other end to the security slot available on Polycom VVX phones, you can prevent your phone from being

stolen or otherwise removed. Refer to the universal security documentation for more information on securing your phone.

Navigating VVX Business Media Phone

The phone has icons, status indicators, and user screens to help you navigate and understand important information on the state of your phone.

Accessing Screens on VVX Business Media Phone

You can access the following screens on the phone:

- Home Screen—Displays your messages, settings, and information.
- Calls Screen—Displays all active and held calls on your line.
- Lines Screen—Displays your phone lines, favorites, and conditional soft keys.
- Active Call Screen—Displays the active call currently in progress.

Access the Home Screen

On VVX phones, the phone lines and icons you can select to access phone features, settings, and information display on the Home screen.

The following figure shows the Home screen on VVX 500 phones.

Home screen on VVX 500 phones

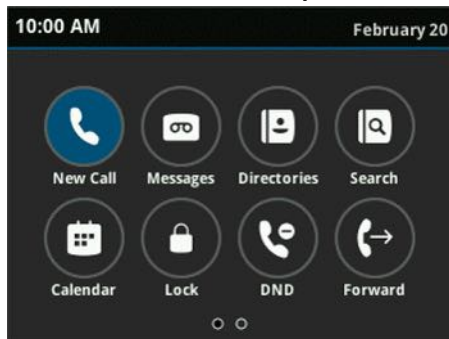

Procedure

1. Press .

Access the Calls Screen

You can access the Calls screen when you have one held call or an active and held call in progress on your phone.

The Calls screen is automatically displayed when you have an active call and one or more held calls on your phone. The total number of calls is displayed on your line, and if you have multiple lines on your phone, calls display under the associated line, as shown next.

Calls screen on VVX 500 and 600 series phones

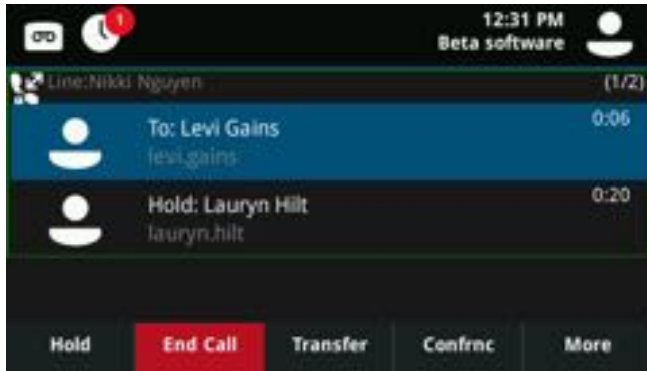

Procedure

1. During a call, do one of the following:
 - Press the Home key .
 - On VVX 201 phones, press the **L > C** soft key.
 - On VVX 500/501 and 600/601 phones, tap **Return to Calls** in the status bar.
 - On VVX 500/501 and 600/601 phones, swipe the screen right to left.

Access the Lines Screen

The Lines screen is the default screen when your phone is not in use. When you have multiple calls on your phone, the number of calls you have is displayed next to the line number.

You can view your phone lines, favorites, and soft keys on the Lines screen, as shown next.

Phone line, favorites, and soft keys on the Lines screen on the VVX 300 series

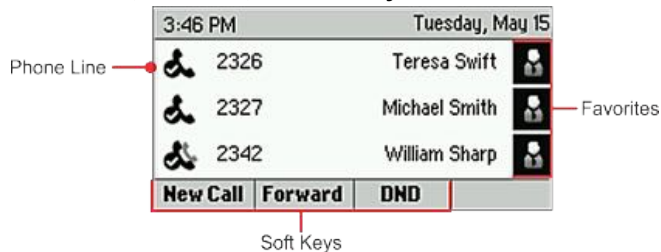

Procedure

1. Press the Home key .

Access the Active Call Screen

The Active Call screen is supported on VVX 500/501, and 600/601 phones, and the screen is displayed when you place a call and have an active call in progress. When you have an active call in progress, the name and number of the contact you are talking with and the duration of the call is displayed. In the Active Call screen, you can hold, end, and transfer the call, or set up a conference call.

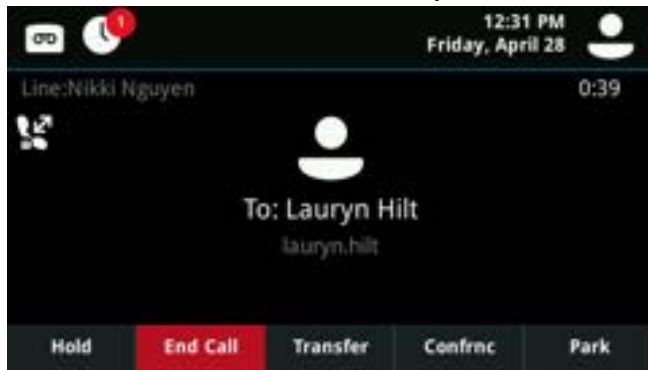
Active Call screen on VVX 500 series phones**Procedure**

1. Do one of the following:
 - Place a call.
 - Press the Home key (🏠) during an active call.
 - Tap **Return to Calls** in the status bar.
 - Swipe the screen from right to left.

Switch among Phone Screens

You can see any phone screen on your phone from other screens by pressing the Home key (🏠), or by swiping your finger from right to left on the touchscreen. Although you can access any phone screen from other screens, you can access certain screens only if your phone is idle or has one or more calls in progress.

You can access certain screens in the following scenarios:

- If your phone is not in use, you can access the Home and Lines screen.
- If your phone has an active call, you can access all screens.
- If your phone has one active call only, you can access the Home, Lines, and Active Call screens.
- If your phone has multiple calls, or one held call, you can access the Home, Lines, and Calls screen.

Procedure



















1. Do one of the following:
 - From the **Home** screen, press (🏠) to display either the Lines, Calls, or Active Call screen.
 - The Calls and Active Call screen display only when an active or held call is in progress on your phone.
 - Press the Home key (🏠) to display the Home screen from the Lines, Calls, or Active Call screen.
 - On VVX 201 phones, press the **C > L** soft key to display the Lines screen from the Calls screen.
 - On VVX 201 phones, press the **L > C** soft key to display the Calls screen from the Lines screen.







- On VVX 500/501 and 600/601 phones, swipe the screen to the right or left to switch between the Lines, Calls, or Active Call screen.

Icons and Status Indicators













The following tables display phone icons and status indicators that display on the VVX business media phones.











Icons on VVX 201 Phones

| Icon | Description | Icon | Description |
|---|------------------------------------|---|-------------------------------------|
|  | Registered line |  | Phone warning |
|  | Unregistered line |  | Login credentials invalid |
|  | Placing a call |  | Shared line |
|  | Active call using Polycom HD Voice |  | Shared line with a held call |
|  | Held call |  | Call forwarding is enabled |
|  | Incoming call |  | New message |
|  | Active conference |  | Presence status (Available) |
|  | Placed call |  | Presence status (Busy or In a Call) |
|  | Received call |  | Presence status (Away) |













| Icon | Description | Icon | Description |
|---|------------------------|---|----------------------------------|
|  | Missed call |  | Presence status (Do Not Disturb) |
|  | Favorite |  | Presence status (Offline) |
|  | Do Not Disturb enabled |  | Presence status (Unknown) |

















Icons on VVX 300 Series Phones

| Icon | Description | Icon | Description |
|---|------------------------------------|---|------------------------------|
|  | Registered line |  | Phone warning |
|  | Unregistered line |  | Login credentials invalid |
|  | Placing a call |  | Shared line |
|  | Active call using Polycom HD Voice |  | Shared line with a held call |
|  | Held call |  | Call forwarding is enabled |
|  | Incoming call |  | New message |
|  | Active conference |  | Presence status (Available) |





| | | | |
|---|------------------------|---|-------------------------------------|
|  | Placed call |  | Presence status (Busy or In a Call) |
|  | Received call |  | Presence status (Away) |
|  | Missed call |  | Presence status (Do Not Disturb) |
|  | Favorite |  | Presence status (Offline) |
|  | Do Not Disturb enabled |  | Presence status (Unknown) |





















Icons on VVX 400 Series Phones

| Icon | Description | Icon | Description |
|---|------------------------------------|---|------------------------------|
|  | Registered line |  | Phone warning |
|  | Unregistered line |  | Login credentials invalid |
|  | Placing a call |  | Shared line |
|  | Active call using Polycom HD Voice |  | Shared line with a held call |
|  | Held call |  | Call forwarding is enabled |
|  | Incoming call |  | New message |

| | | | |
|---|---|---|---|
|  | Active conference |  | Presence status (Available) |
|  | Placed call |  | Presence status (Busy or In a Call) |
|  | Received call |  | Presence status (Away) |
|  | Missed call |  | Presence status (Do Not Disturb) |
|  | Favorite |  | Presence status (Offline) |
|  | Do Not Disturb enabled |  | Presence status (Unknown) |
|  | USB flash drive attached (VVX 401/411 only) |  | Recording paused (VVX 401/411 only) |
|  | Recording in progress or paused (VVX 401/411 only) |  | Recording in progress (VVX 401/411 only) |

Icons and Status Indicators on VVX 500 Series and 600 Series Phones

| Icon | Description | Icon | Description |
|---|-------------------|--|---|
|  | Registered line |   | Status indicators in Lines screen. A flashing red bar indicates held calls. A green bar indicates an active call. |
|  | Unregistered line |  | Do Not Disturb enabled |

| Icon | Description | Icon | Description |
|---|--|---|----------------------------------|
|  | Placing a call |  | Phone warning |
|  | Active call using Polycom HD Voice |  | Login credentials invalid |
|  | Held call |  | Shared line |
|  | Incoming call |  | Call forwarding is enabled |
|  | Active conference |  | Recent calls |
|  | USB flash drive attached |  | USB flash drive in use |
|  | Placed call |  | Presence status (Available) |
|  | Received call |  | Presence status (Busy) |
|  | Missed call |  | Presence status (Away) |
|  | Bluetooth available (VVX 600/601 only) |  | Presence status (Do Not Disturb) |
|  | Bluetooth disconnected (VVX 600/601 only) |  | Presence status (Offline) |

Related Links

[Features for Hearing-Impaired Users](#) on page 145

Entering Information in Data Fields

You can enter information and edit fields using the dial pad keys on the phone console or using the onscreen keyboard on VVX 500/501, and 600/601 phones.

Before you enter information into fields, you can choose how to enter the information using the following soft keys:

- **Mode**—Enables you to enter just numbers or text in title case, lowercase, or uppercase characters.
- **Encoding**—Enables you to enter alphanumeric and special characters as well as characters in special languages.

The following table lists the Mode and Encoding options for the dial pad and the onscreen keyboard.

Mode and Encoding Options

| Mode Options | Encoding Options |
|--|---|
| Abc (to capitalize the first letter only, and use lowercase for the remaining letters) | Abc |
| ABC (to enter uppercase only) | ABC |
| abc (to enter lowercase only) | abc |
| 123 (to enter numbers only) | 123 |
| | ASCII (for regular text) |
| | Latin (to enter accented characters) |
| | Katakana (for Japanese characters) |
| | Unicode (to store characters as double bytes) |
| | Cyrillic (for Russian characters) |

When the onscreen keyboard is displayed, the Encoding and Mode soft keys are not available.

Entering Information Using the Dial Pad

You can use the dial pad keys on your phone console to edit or update field information. The following table describes how to enter different types of data on your phone using the dial pad.

Using the Dial Pad Keys to Enter Information

| Data Type | Action |
|--|---|
| Enter numbers, or characters in uppercase, lowercase, or title case mode | Select Encoding or Mode , and select ABC,abc, or Abc. |



| | |
|--------------------------------|---|
| Enter only numbers | Select Encoding or Mode , and select 123 . |
| Enter text in another language | Select Encoding , and select one of the language options. |
| Enter a character | Press a dial pad key repeatedly to view the character options and stop when the character you want to enter is displayed in the field. Wait one second, and enter the next character. |
| Enter a number | Select Encoding or Mode , and select 123 , or press a dial pad key repeatedly to enter the number that displays on that key. |
| Enter a special character | <p>Select Encoding, and select Abc, ABC, or abc. Press the 1, 0, asterisk, *, or pound # key one or more times to enter one of the following special characters:</p> <ul style="list-style-type: none"> • 1 key: ! ' ^ \ @ : 1 • * key: * - & % + ; () • 0 key: / , _ \$ ~ = ? 0 • # key: # > < { } [] " ' ` <p>You cannot access special characters when you are in numerical (123) mode.</p> |
| Enter a space | <p>Select Encoding, and select one of the alphabetic Abc, ABC, or abc. Press the 0 key.</p> <p>You cannot enter a space when you are in numerical (123) mode.</p> |
| Delete one or more characters | <p>Use the arrow keys to position the cursor to the right of the character, or drag your finger across the characters until the cursor is positioned to the right of the character(s) you want to delete. Press the Delete key, press the << soft key, or tap .</p> |

Enter Information Using the Onscreen Keyboard

The onscreen keyboard available on VVX 500 and 600 phones enables you to enter information into text fields using the touchscreen.



The onscreen keyboard displays on screen automatically when a text field is shown. When a text field requires only numbers, the onscreen keyboard displays only numbers.

Procedure

1. Tap .
2. Tap  and select **Abc**, **ABC**, **abc**, **123**, or one of the special character options.
3. Press your finger on each character you want to enter.
4. When you finish, tap .

The following table describes how to enter information using the onscreen keyboard.

Using the Onscreen Keyboard to Enter Information

| Task | Action |
|---|---|
| Select an Encoding option (title case, uppercase, lowercase, numbers-only, ASCII, Latin, Katakana, Unicode, Cyrillic) | Tap  and select the Encoding options you want. |
| Enter text | Tap Abc and select the characters you want. |
| Enter uppercase characters | Tap ABC and select the characters you want. |
| Enter lowercase characters | Tap abc and select the characters you want. |
| Enter numbers | Tap 123 and select the numbers you want. |
| Enter special characters | Tap ASCII and select the characters you want. |
| Exit the onscreen keyboard, enter the information, and update the next field | Tap  . |
| Delete one or more characters | Drag your finger across the characters to highlight them in yellow then tap  . |
| Replace characters | Highlight the characters you want to replace then enter the new characters. |

Entering Chinese Characters with PinYin

PinYin is a commonly used method for inputting Chinese characters. The PinYin text input feature on VVX business media phones uses Nuance XT9 Smart Input to enable you to enter Chinese characters into text fields using the phone's dial pad keys or onscreen keyboard.

Note: For more information on the PinYin text input method, see the [Nuance's XT9 Smart Input](#) web site.

Using the PinYin Input Widget

You can enter Chinese characters in the contact directory, corporate directory, and browser using the PinYin input widget and the dial pad keys or onscreen keyboard. When you select a data field to edit, the PinYin input widget is automatically displayed when Simplified or Traditional Chinese is set as the displayed language on your phone.

Enter Chinese Characters with the Dial Pad Keys

You can use the dial pad keys and the PinYin input widget to enter Chinese characters on your phone. The PinYin input widget disappears if you press the Pound key  or no keys are pressed for 5 seconds.

Procedure

1. Enter the PinYin text that corresponds with the letters on the phone's dial pad.
For example, press 7464.

The possible PinYin matches display in the text field with the first match highlighted.

2. Press the Star key  to toggle between selections.



The recommendation area shows the possible character matches. A navigation indicator is displayed if more matches are available.

3. Use the left and right arrow keys or swipe the recommendation area on the touch screen to change the selected character.
4. Press the **Select** key to select the character from the recommendation area.
5. After the character is selected, it is displayed in the input field at the cursor location.
6. Repeat preceding steps until entry is complete.

Enter Chinese Characters with the Onscreen Keyboard

You can use the onscreen keyboard and the PinYin input widget to enter Chinese characters on your phone.

Procedure

1. Tap .
2. Tap  to verify that PinYin is the default input mode.
A list of language options display.
3. Ensure that **XT9 PinYin** is selected.
4. Enter the PinYin text using the onscreen keyboard.
5. Tap  on the onscreen keyboard to select the character from the recommendation area.
6. Repeat preceding steps until entry is complete.

Logging Into and Locking Your Phone

Topics:

- [Signing into Skype for Business](#)
- [Locking Your Phone](#)

VVX business media phones enable you to sign into the phone with your Skype for Business credentials, or lock your phone.

Signing into Skype for Business

You can use one of the following methods to sign in to a Polycom phone with your Skype for Business credentials:

- User ID—enter your user credentials.
- PIN—enter your PIN Authentication credentials, if enabled.
- Via PC—when your phone is paired to your computer using Better Together over Ethernet (BToE), use the Skype for Business client to sign in.
- Web Sign In—when you have a Skype for Business Online account, use the unique website shown on the phone to sign in.

Sign In Using Your Skype for Business User Credentials

You can sign in to your Skype for Business account using your login credentials, which includes your domain, email, username, and password.

Your system administrator provides you with your login credentials.

Procedure

1. Select **Sign In**, or navigate to **Settings > Features > Skype for Business > Sign In**.
2. Select **User ID**.
3. Enter your user credentials for your Skype for Business account, then select **Sign In**
A confirmation message is displayed when the phone successfully signs into Skype for Business.

Note: If you input the wrong credentials and lock your account, contact your system administrator.

Sign Into Skype for Business on Your Computer Using BToE

When your phone is connected to your computer and paired using Better Together over Ethernet (BToE), you can sign into the phone using the Skype for Business client on your computer.

Procedure

1. Select **Sign In**, or navigate to **Settings > Features > Skype for Business > Sign In**.

2. Select **Via PC** or **Paired with Client**.
3. In the Skype for Business client on your computer, enter your login credentials.
A confirmation message is displayed when the phone successfully signs into Skype for Business.

Sign In Using Your Skype for Business PIN Authentication

You can sign into your Skype for Business account using your PIN Authentication credentials, which your system administrator provides.

Procedure

1. Select **Sign In**, or navigate to **Settings > Features > Skype for Business > Sign In**.
2. Select **PIN Authentication**.
3. Enter your PIN Authentication credentials for your Skype for Business account, then select **Sign In**.
A confirmation message is displayed when the phone successfully signs into Skype for Business.

Note: If you input the wrong credentials and lock your account, contact your system administrator.

Sign Into Skype for Business Using Web Sign In

Use the Web Sign In method to sign in to a phone with your Skype for Business Online account using a web browser.

Procedure

1. Select **Sign In**, or navigate to **Settings > Features > Skype for Business > Sign In**.
2. Select **Web Sign In**.
An web address displays.
3. On your computer, enter the URL into your web browser.
4. On the Skype for Business Authentication website, enter your email address, then select **Verify Email**.
5. Enter the PIN generated on the phone into the web browser.
A confirmation message is displayed when the phone successfully signs into Skype for Business.

Set the Time and Date Format

After you sign into your phone with your Skype for Business credentials, you have the option to set the time zone and select a time and date format.

If you do not choose to set up your phone when you first sign in, you can set the time and date formats later.

Procedure

1. After you sign into Skype for Business on your phone, select **Next**.
2. On the Customize Time Zone screen, select your time zone and press **Next**.

3. On the Customize Time Format, choose a time format and press **Next**.
4. On the Customize Date Format screen, choose a date format and press **Next**.

Related Links

[Change the Time and Date Format](#) on page 105

Sign Out of Skype for Business

If you are signed into Skype for Business on a public phone, make sure you sign out of your account after you finish using it.

After you sign out of Skype for Business, you cannot call or view your Skype for Business contacts. However, you can still use other available features.

Procedure

1. Select **Sign Out** or navigate to **Settings > Features > Skype for Business > Sign Out**.

Locking Your Phone

Your system administrator provides you with a user password that you can use to unlock the phone.

Consider locking your phone if you want to:

- Prevent unauthorized outgoing calls.
- Prevent people from viewing or modifying phone information, such as your directory, call lists, or favorites.

When your phone is locked, you can:

- Place outgoing calls to a contact, unless your system administrator restricts your phone to placing calls to emergency and authorized numbers only.
- Answer incoming calls, unless your administrator has set your phone to require a password to answer calls.

Related Links

[Answer a Call on a Locked Phone](#)

[Place a Call from a Locked Phone](#) on page 38

Set a Lock Code

When you sign into your Skype for Business account, you are prompted to set a lock code. After you set a lock code, you can use the code to unlock your phone.

Note: You cannot dismiss the prompt to create a lock, however, the prompt will disappear if you do not create a lock code in a set amount of time. If you do not create a lock code when prompted, you will be automatically signed out of the phone, and you must create a lock code when you sign in again.

Procedure

1. Create and enter a numerical lock code.
2. Confirm your lock code.

Your lock code is set, and you can use your lock code to unlock your phone.

Lock Your Phone

After you create a lock code, you can lock your phone anytime you leave your desk. Your phone also automatically locks after being idle for a set amount of time, which is set by your system administrator.

Procedure

1. Do one of the following:
 - Select the **Lock** soft key.
 - From the Home screen, select **Lock**.
 - Navigate to **Settings > Basic > Device Lock** then select **Lock Now**.

On VVX 400, 500, and 600 series phones, the Lock screen displays with your user name, phone number, and profile photo, if set for your Skype for Business or Microsoft Exchange account, as shown next on VVX 400.

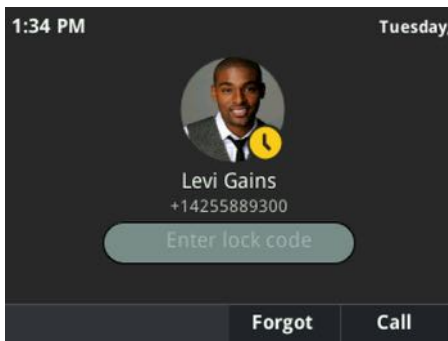

Related Links

[Answer a Skype for Business Call on a Locked Phone](#) on page 41

[Adding a Profile Photo to Display on the Lock Screen](#) on page 117

[Place a Call from a Locked Phone](#) on page 38

Unlock the Phone

You can unlock your phone using your lock code.

Procedure

1. Enter your lock code and select **Unlock** or tap .

Change Your Lock Code

You can change your lock code at any time while signed into your Skype for Business account.

Procedure

1. Navigate to **Settings > Basic > Device Lock**.
2. Select **Change Lock Code** and enter your current lock code.

3. Enter a new lock code and confirm your new lock code.
4. Select **Submit**.

Reset Your Lock Code

If you forget your lock code, you can reset the code from a phone using your login password.

Procedure

1. On the Lock screen, select **Forgot** or tap .
2. On the Forgot Lock Code screen, enter your login password or PIN for your Skype for Business account.
3. Enter and confirm your new lock code.

Disable Device Lock

Device Lock is enabled by default, however, if you do not want to lock your phone, you can disable Device Lock.

Procedure

1. Navigate to **Settings > Basic > Device Lock**.
2. Select **Device Lock: Enabled**, and select **Disabled**.

Audio Calls

Topics:

- [Placing and Answering Audio Calls](#)
- [Switch among the Handset, Headset, and Speakerphone](#)
- [Mute and Unmute Audio](#)
- [Holding and Resuming Calls](#)
- [End an Active Audio Call](#)
- [Transferring Calls](#)
- [Parking and Retrieving Calls on the Skype for Business Server](#)
- [Managing Calls](#)
- [Ignoring or Rejecting Incoming Calls](#)
- [Redirecting Incoming Calls](#)

VVX business media phones enable you to place and answer SIP calls, ignore incoming calls from all or individual contacts, and perform server-dependent tasks.

Note: Some of the features described in this section require access to the Basic settings menu on the phone. If your phone requires a password to access the Basic settings menu, contact your system administrator for assistance customizing your phone.

Placing and Answering Audio Calls

VVX 201 phones can manage a maximum of 8 active, incoming, and held audio calls at a time. VVX 300 series, 400 series, 500 series, and 600 series phones can manage a maximum of 24 active, incoming, and held audio calls at a time. However, you can have only one active call in progress with numerous other incoming calls or calls on hold on all phones. Additionally, your system administrator can set up your phone to have up to six lines with unique extension numbers, or the same extension number as other lines on your network.

Placing Audio Calls



You can place calls on VVX Business Media Phone in numerous ways, including international calls, calls from Recent Calls or directories, calls to contacts or favorites, calling a contact from a VVX Expansion Module, or calling authorized numbers on a locked phone.

Place a Call from the Dialer

The Dialer enables you to enter a number to place a call and displays a list of previously placed calls. As you enter numbers, the Dialer displays a list of similar numbers in your directory, and you can select a match to automatically enter the number.

Note: Your administrator can set up your phone to automatically place the call after you enter a certain number of digits. If a call is placed before you enter all the digits, add the number to your Contact Directory and dial the number from the Contact Information screen.

Procedure

1. Do one of the following:
 - Start typing a phone number.
 - Select **New Call**.
 - Press a line key.
 - Pick up the handset, press , or press .
2. Enter a number or select a recent contact.
3. Select **Dial** or tap .

Place an International Call

You can place calls to international phone numbers from the Dialer.

Procedure

1. On the dial pad, quickly press the **star key** * twice.
A plus sign + is displayed.
2. Enter the remainder of the number and press **Dial** or tap .

Place a Call from Recent Calls

You can place calls to contacts from the Recent Calls list, which contains calls that were recently placed, answered, or missed.

Procedure

1. Do one of the following:
 - On VVX 201, 300 series, and 400 series phones, navigate to **Directories > Recent Calls**.
 - On VVX 500/501 and 600/601 phones, tap **Directories > Recent**.
2. From the **Calls List** screen, select a contact and select **Dial**.
On VVX 500/501 and 600/601 phones, the call is automatically placed after you select a contact.

Calling Favorites

You can call your favorites from the Favorites list or by selecting a favorite on your Home or Lines screen.

Call Favorites from the Favorites List

When you add a contact as a favorite, the contact is added to your Favorites list, and you can call contacts directly from the Favorites list.

Procedure

1. Select **New Call**.
2. From the **Dialer**, select **Favorites**.
3. Select a favorite, and select **Dial**.

On VVX 500/501 and 600/601 phones, the call is automatically placed after you select a favorite.

Call Favorites from the Home or Lines Screen

You can quickly call favorites from the Home or Lines screen.

Procedure

1. Do one of the following:
 - On VVX 201, 300 series and 400 series phones, press a line key associated with a favorite on the Lines screen.
 - On VVX 500/501 and 600/601 phones, press , tap your phone line, and tap a favorite.

A call is placed to the favorite automatically.

Calling Contacts from the Directory

You can search for and call contacts in your Contact Directory, the Corporate Directory, and the Skype for Business Directory. You can also search for distribution lists and call a member of a distribution list.

Call a Contact from a Directory

You can place a call to a contact directly from your directory or you can select contacts in your directory to call from the New Call screen.

Procedure

1. Do one of the following:
 - Select **Directories**.
 - Navigate to **New Call** > **Directory**.
2. Choose a directory.
3. From your directory, select or search for a contact.
4. Select the contact's phone number.

The call is automatically placed on VVX 500/501 and 600/601 phones.
5. On VVX 201, 300 series, and 400 series, select **Dial**.

Call a Contact from the Directory Search Screen

You can search for and call contacts from the Search screen in your directory.

Procedure

1. Select **Directories**.
2. Select **Search**, enter your contact's first or last name, and select **Search**.

3. Select your contact.
4. In the **Contact Information** screen, select the contact's number, and select **Dial**.

Call a Member of a Distribution List

You can call a member of a distribution list (DL) directly.

Procedure

1. Navigate to **Directories > Contacts > Groups**.
2. Select a DL, then select **Expand**.
3. Select your member of the DL, then select **Dial**.

Related Links

[Search for Skype for Business Distribution Lists](#) on page 80

Place a Call from a Locked Phone

When the phone is locked, you can place outgoing calls to any contact unless your system administrator restricts your phone to placing calls only to emergency numbers, such as 911, and authorized numbers that your administrator can set up.

Procedure

1. Select **Call** .
2. From the **Place an Authorized Call** screen, select a number, and select **Dial**.

Related Links

[Locking Your Phone](#) on page 32

[Lock Your Phone](#) on page 33

Placing Intercom Calls

The Intercom feature enables you to place a call to a contact that is answered automatically on the contact's phone as long as the contact is not in an active call. If the contact is in an active call, the contact can choose to answer the intercom call, or the intercom call is answered automatically after the active call ends.

Check with your system administrator to find out if this feature is available in your environment.

Place an Intercom Call

You can place an intercom call to a contact to quickly relay a message.

Procedure

1. From the Home screen, select the **Intercom** icon or select the **Intercom** soft key.
2. Enter a number or select a contact.
3. Select **Dial** or tap  .

The phone plays a tone and the call is answered automatically on the contact's phone.

4. Speak your message and wait for a response.

5. If you do not need to wait for a response, select **End Call** .

Tip: Your system administrator can set up your phone to automatically call a specific contact when you select Intercom. If your phone is set up this way, select Intercom and wait for your contact to answer before speaking your message.

Place an Intercom Call During a Call

You can place an intercom call to another contact during an active call.

Procedure

1. Select **Hold**, and select **Intercom**.
The active call is placed on hold and the Dialer is displayed.
2. Enter a number or select a contact.
3. Select **Dial** or tap .
4. After the call is answered, speak your message and select **End Call Hang Up**.
5. Select **Resume**.

Place a Call from a VVX Expansion Module

You can place a call using the line keys on your VVX Expansion Modules. Line keys on expansion modules activate available lines and place calls to contacts assigned to those lines.

Procedure

1. Do one of the following:
 - Press a line key corresponding to an available line and dial the number.
 - Press the line key of the assigned favorite you want to call.

The call is placed and is displayed on your phone's screen.

Related Links

[Connecting Polycom VVX Expansion Modules to Your Phone](#) on page 130

Redial a Number

Your phone automatically keeps a record of all the calls placed, and you can recall the last contact you call using Redial.

Procedure

1. Do one of the following:
 - Select **Redial** on the Home screen.
 - Press the **Redial** soft key.

Answering Audio Calls

When you receive an incoming call, you can choose to answer the call in various ways, including answering calls in the Incoming Calls screen, in the Calls screen, during a call, and automatically.

Answer an Incoming Call



When you receive an incoming call, the phone rings and an Incoming Call screen is displayed, as shown next. In the Incoming Call screen, you can choose to answer or reject the incoming call.

Incoming Call window



Note: Your system administrator can enable the screen to flash bright orange when you have an incoming call. The screen continues to flash until the incoming call is displayed in the Home or Calls screen. For more information about this feature, contact your system administrator.

Procedure

1. Do one of the following:
 - Pick up the handset.
 - Press  or select **Answer**.
 - Press .

After you answer the incoming call, the call becomes active.

Answer a Call from the Calls Screen

When you don't answer an incoming call within 10 seconds, the Incoming Call screen disappears, and the Calls screen is displayed.

Procedure

1. Select the incoming call, and select **Answer**.

Answer a Call When in a Call

When you are in an active call and an incoming call arrives on the same or a different line, a call waiting tone beeps, and the Incoming Call screen is displayed.

If you don't answer the call within 10 seconds, the Incoming Call screen disappears, and the Calls screen is displayed.

Procedure

1. Select **Answer**.

The active call is placed on hold, and the incoming call becomes active.

Answer Calls Automatically

You can set up the phone to automatically answer calls using the Auto Answer feature. When enabled, the phone automatically answers all incoming calls using the speakerphone. Your system administrator sets how many times the phone rings before the call is automatically answered.

When Auto Answer is enabled and you receive an incoming call while in a call, the incoming call is not answered until you end or hold the current call.

Procedure

1. Navigate to **Settings > Basic > Preferences**.
2. Select **Auto Answer**.
3. Select **Auto Answer SIP Calls** and select **Yes**.
4. Select **Microphone Mute** and choose **Yes** (the default setting) to mute the microphone for auto-answered calls.
5. Select **Save**.

Related Links

[Features for Mobility-Impaired Users](#) on page 146

Answer a Skype for Business Call on a Locked Phone

You can answer incoming calls without unlocking the phone. However, when you answer a call without unlocking the phone first, you cannot perform additional call actions, such as hold, resume, or transfer calls, until you unlock the phone. The only soft keys available during the call are the End Call and Unlock soft key.

You can unlock the phone at any time during the call.

Procedure

1. Select **Answer**.

Related Links

[Lock Your Phone](#) on page 33

Answer an Intercom Call

When you receive an intercom call, the call is answered automatically using the speakerphone.

You can switch to the handset or headset after the call is answered.

If the phone is set up to answer intercom calls with your microphone muted, you need to unmute your microphone before responding to the call.

Procedure

1. After the call is answered, press  **Mute** and reply.

Answer a Call from a VVX Expansion Module

You can answer calls using the line keys on your VVX phone or from your VVX Expansion Module.

Procedure



1. Press the expansion module line key with a flashing green LED indicator.

Related Links



[Connecting Polycom VVX Expansion Modules to Your Phone](#) on page 130



Switch among the Handset, Headset, and Speakerphone

You can place and answer calls on your phone using the handset, speakerphone, or headset. You can alternate among the three modes during calls, if available.

When using the speakerphone, the Speakerphone key  glows green. When using the headset, the Headset key  glows green if an analog headset is connected or blue if a USB headset is connected. For VVX 201 phones, the headset and speakerphone keys do not glow and the Headset  icon displays in the status bar.

Procedure

1. During a call, pick up the handset, press the Headset key  or press the Speakerphone key .

For example, if you're using the handset, press the Headset key  to switch to the headset, or press the Speakerphone key  to switch to the speakerphone.

Related Links

[Use Your Headset for All Calls](#) on page 119

Mute and Unmute Audio

You can mute the microphone so other parties cannot hear you. Microphone Mute applies to the handset, headset, and speakerphone. You can still hear all other parties when you mute your microphone. When your audio is muted, the Mute icon is displayed, and the Mute key glows red, excluding VVX 201 phones.

Procedure

1. During a call, including a conference call, press .

The other parties cannot hear you.
2. Press  again to unmute the microphone.

Holding and Resuming Calls

When you are in a call, you can place an active audio call on hold and resume the call.

Hold a Call

You can place any active call on hold.

Procedure

1. During an active call, select **Hold**.

If you're in the Calls screen, select the call first.

A hold icon  is displayed on the line of the held call, and a red LED light flashes on the line key for all phones except VVX 201 phones.

Resume a Call

You can view and resume all held calls in the Active Call and Calls screens.

Procedure

1. Do one of the following:
 - Select **Resume**.
 - From the Calls screen, select the call, and select **Resume**.

Resume a Call on a VVX Expansion Module

You can resume calls placed on hold by other contacts from your VVX Expansion Module. A flashing red LED light on a line key on the expansion module indicates a call is on hold on the contact's line.

Procedure

1. Press the line key corresponding to the line with the held call.

End an Active Audio Call

You can end an active call on your phone at any time.

Procedure

1. Do one of the following:
 - Place the handset on the cradle.
 - Press **End Call**.
 - In the Calls screen, highlight the call and press **End Call**.

End a Held Call

You cannot end calls that are on hold. You must resume held calls before ending them.

Procedure

1. From the Calls screen, select the held call and press **Resume > End Call**.

Transferring Calls

You can transfer active or held calls to another person using the following transfer types:

- Blind transfer—Transfers the call directly to another line without speaking with the other party first.
- Consultative transfer—Enables you to speak with the other party before completing the transfer.

Related Links

[Hold a Call Privately on a Shared Line](#) on page 59

Choose a Default Transfer Type

You can choose a default transfer type to use for all calls.

When you choose a default transfer type, and the phone uses the set transfer type for all calls. Consultative is set as the transfer type by default.

Procedure

1. Navigate to **Settings > Basic > Preferences**.
2. Select **Default Transfer Type** and choose a transfer type.
The selected transfer type is used for all calls.

Transfer a Call

You can transfer a call to another contact and choose the transfer type you want to use for the call.

Procedure

1. During a call, do one of the following
 - Press **Transfer** to use the default transfer type.
 - Press and hold **Transfer** to use the non-default transfer type.
For example, if Blind is the default, press and hold Transfer to perform a Consultative transfer.
 - Press **Transfer > More**, and select **Blind** or **Consultative**.
Depending on the default transfer type, either the Blind or Consultative option displays. For example, if the default transfer type is Blind, then you can select Consultative.
2. Dial a number or choose a contact from the Recent Calls or a directory.
If the transfer type is set to Blind, the call is transferred immediately.
3. If the transfer type is set to Consultative, select **Transfer** after speaking with your contact.

Cancel a Transfer

If a contact does not answer the transfer or you want to remain speaking with the contact on your line, you can cancel the transfer before it is complete.

Procedure

1. Select **Cancel**.
The call is not transferred and becomes active.

Parking and Retrieving Calls on the Skype for Business Server

Using the Skype for Business Call Park feature, you can park up to eight calls while you continue to make calls and answer other incoming calls on your phone. Call Park is different from call hold in that the call is placed in a call orbit on the Skype for Business Server. Calls placed in the call orbit are given a retrieval number and can be retrieved by any Skype for Business-compatible phone with access to the orbit.

Park Skype for Business Calls

You can park up to eight active or held calls on your line. If you try to park additional calls, a message displays stating that the maximum number of calls have been parked on the server.

Procedure

1. During a call, press the **Park** soft key.
The call is placed in the call orbit and given a retrieval number, as shown next.

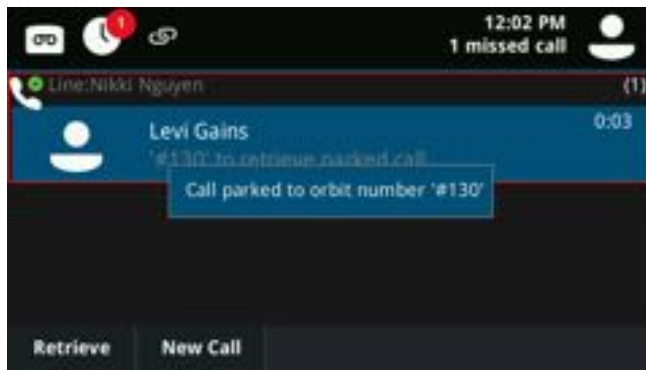

After you park a call, you can retrieve the call or provide another contact with the call retrieval number to retrieve the call.

Retrieving Parked Skype for Business Calls

Parked calls are placed in the call orbit and given a retrieval number to retrieve the call. When someone retrieves a parked call, a notification showing that the call was picked up and by whom is shown on the phone of the person who parked the call.

If no one retrieves a parked call within a set time limit, the call is returned to the person who parked the call. For example, if Betty parked a call and no one retrieves the call, the server returns the call to Betty's line. If Betty doesn't answer the parked call after it's returned, the call is sent to the default line on the server. If the call is not answered, the call is terminated. The time limit for parked calls and the default line are set by the system administrator.

Retrieve a Parked Skype for Business Call on Another Phone

You or anyone on your network can retrieve a parked call by dialing the retrieval number.

Procedure

1. Select **New Call** and dial the retrieval number.

For example, dial #1347.

Retrieve Parked Skype for Business Calls on the Same Phone

You can retrieve a parked call on the same phone where the call was parked.

Procedure

1. Do one of the following:
 - Press the **Retrieve** soft key.
 - Select **New Call** and dial the retrieval number. For example, dial #1347.

Managing Calls

On VVX phones, you can see the number of calls on the line from the Lines screen, as shown next. On all VVX business media phones, a green light on the line key indicates a line with an active call, and a red light indicates a line with one or more held calls.

Multiple Calls on phone lines on the Lines screen



Display Calls from the Lines Screen

You can display the calls for each line from the Lines screen.

When you select a phone line that does not have an active call, the first held call on that line is automatically resumed, even if you already have an active call on a different line.

Procedure

1. Do one of the following:
 - Press and hold the line key.
 - Tap and hold the phone line.
 - On VVX 500/501 and 600/601 phones, swipe the screen from right to left.

Display Calls from the Calls Screen

You can also view multiple calls on your line from the Calls screen.

Procedure

1. Do one of the following:
 - On VVX 201 phones, press the **L > C** soft key.
 - From the **Lines** or **Home** screen, press .
 - On VVX 500/501 and 600/601 phones, tap **Return to Calls** in the status bar.

The Calls screen is displayed with the list of active and held calls for each line on the phone.

Manage a Call from the Calls Screen

From the Calls screen, you can manage a call by holding, resuming, or transferring the call.

Procedure

1. Select a call.
2. Do one of the following:
 - Select **Hold** to place an active call on hold.
 - Select **Resume** to make a held call active.
 - Select **End Call** to end a call with a contact. You can end active calls only, so resume the held call first before ending it.
 - Select  **Transfer** to send the call to another contact.
 - Select **Conference** to initiate a conference call.

Ignoring or Rejecting Incoming Calls

When you receive an incoming call, you can choose to ignore or reject the call instead of answering. You can reject or ignore incoming calls, reject incoming calls from a specific contact, or enable Do Not Disturb to reject all calls for a brief time period.

Note: You cannot reject calls on shared lines. You can only silence the ringer.

Ignore or Silence an Incoming Call

You can ignore or silence a call to stop your phone from ringing. Even if you ignore the call and silence the ringer, an incoming call notification continues to display on your phone.

Procedure

1. From the **Incoming Call** screen, do one of the following:
 - Select **Ignore** for private lines.
 - Select **Silence** for shared lines.

The **Incoming Call** screen disappears, your phone stops ringing, and either the Home or Calls screen is displayed.

Reject Incoming Calls

You can reject a call and send the call directly to voicemail. Rejected calls display in the Missed Calls list in your Recent Calls list. Rejecting calls is not available for shared lines.

Procedure

1. From the **Incoming Call** screen, select **Reject**.

The call goes directly to voicemail.

Reject Calls from a Contact

You can send incoming calls from a particular contact directly to your voicemail.



Procedure

1. Navigate to **Directories > Contact Directory**.
2. From your **Contact Directory**, select a contact.
3. From the **Contact Information** screen, select **Edit** or tap .
4. From the **Edit Contact** screen, select **Auto Reject > Enabled** and select **Save**.

Calls from the contact are sent directly to voicemail when the contact calls.

Rejecting Calls with Do Not Disturb

When you enable Do Not Disturb (DND), the following occurs:

- The DND icon  displays in the status bar.
- When the phone is idle, the DND icon is displayed next to your phone line on the Lines screen. If you have new messages or call forwarding is enabled, the messages or forwarding icon is displayed instead.
- The message “Do Not Disturb” is displayed in the status bar on all phones.
- The DND icon on the Home screen changes from  to .

For VVX 101 and 201 phones, the line icon changes to .

Note: When you set your presence status to Do Not Disturb, as well as enable DND for your phone, the message "My Status: Do Not Disturb" scrolls under the time display, and the DND icon does not display in the status bar.

Enable Do Not Disturb

You can enable DND to prevent your phone from ringing and to send all incoming calls directly to voicemail. All calls you receive while DND is enabled are logged in your Recent Calls list.

Enabling DND on shared lines disables ringing only. A visual notification of the call still displays, and you have the option to answer or ignore the call.

Procedure

1. Select **DND**.

Reject Calls with Do Not Disturb on Multiple Lines

By default, the Do Not Disturb feature applies to all lines on your phone. Your system administrator can set up your phone so that you can enable the feature on a per-line basis.

Procedure

1. Select **DND**.
2. Select **Set All** to enable DND for all lines.

Reject Calls with Do Not Disturb on One Line

If enabled, you can choose to enable DND for a particular line and not all lines.

Procedure

1. Select **DND**.
2. From the **Line Select** screen, select a line.
3. From the **Do Not Disturb** screen, select **Enable**.

Redirecting Incoming Calls

You can redirect incoming calls by forwarding an incoming call to a contact, forwarding all incoming calls to a contact, or diverting calls from a specific contact to another contact.

Forwarding Incoming Skype for Business Calls

When your phone is registered with Skype for Business Server, you have more options for forwarding calls, which includes forwarding calls to contacts, voicemail, or a group of contacts.

Forward Skype for Business Calls to a Contact

You can set up a phone to forward all your calls to one of your Skype for Business contacts.

Procedure

1. Select **Forward > Forward to a Contact**.
2. Enter a contact's number.

A scrolling message showing that you have forwarded all incoming calls to your contact is displayed on your phone.

Forward Skype for Business Calls to Voicemail

When you are signed into Skype for Business, you have the option to forward calls directly to your voicemail.

Note: The Forward to Voicemail option is available only when voicemail is enabled. If voicemail is disabled, you cannot select the Forward to Voicemail option.

Procedure

1. Select **Forward > Forward to Voicemail**.
All incoming calls are sent directly to your voicemail.

Simultaneously Ring a Group of Contacts

In the Skype for Business client, you can choose to simultaneously ring a group of Skype for Business contacts when you receive incoming calls.

Procedure

1. In the Skype for Business client, click  and select **Tools > Call Forwarding Settings**.
2. Select **Simultaneously Ring > My Team-Call Group**.
3. In the **Call Forwarding - My Team-Call Group** dialog box, click **Add**.
4. In the **Choose a Team-Call Group Member** dialog box, select the contacts you want to add and click **Ok**.
The contacts you add as group members are displayed in the **Call Forwarding - Team-Call Group** dialog box.

5. Click the **Ring your team-call group after this many seconds** drop-down menu to determine when your contacts' phones ring.

Simultaneous ringing is enabled for all assigned team-call members. If your line receives an incoming call, everyone in the team-call group phones ring.

Forward Calls to Delegates

If you have delegates assigned to your line, you can forward all incoming calls directly to your delegates.

Procedure

1. Select **Forward > Forward to Delegates**.

Related Links

[Assign Delegates](#) on page 61

Simultaneously Ring Delegates

If you have delegates assigned to your line, you can enable your delegates' phones to simultaneously ring when you receive incoming calls.

Procedure

1. Select **Forward > Simultaneously Ring My Delegates**.

Divert Calls to a Contact

You can divert all incoming calls from a particular contact to another contact.

Procedure

1. Select **Directories > Contact Directory**.
2. From the **Contact Directory**, select a contact.
3. From the **Contact Information** screen, select **Edit** or tap .
4. From the **Edit Contact** screen, select **Divert Contact**, and enter a contact's number.
5. Select **Auto Divert > Enabled**.
6. Select **Save**.

Conference Calls

Topics:

- [Tips for Conference Calls](#)
- [Initiating a Skype for Business Conference Call](#)
- [Initiating a Group Conference Call](#)
- [Add Contacts to a Skype for Business Conference Call](#)
- [Send Contacts Active Conference Information](#)
- [Viewing a List of Skype for Business Conference Participants](#)
- [Managing Skype for Business Conference Participants](#)

When you are signed into Skype for Business on your VVX business media phone, you can initiate audio conference calls with your Skype for Business contacts from your phone. You can also manage conference participants, enable announcements, and lock a conference.

You can manage a maximum of eight Skype for Business conference calls on VVX 201 phones and 24 Skype for Business conference calls at a time on VVX 300 series, 400 series, 500 series, and 600 series phones. However, you can have only one active audio conference call in progress on your phone.

Related Links

[Hold a Call Privately on a Shared Line](#) on page 59

Tips for Conference Calls

When you are in a conference call, follow these tips:

- Use the handset or a headset if you're in an open environment.
- Mute your microphone when you are not speaking, especially in noisy environments.
- Avoid tapping or rustling papers near the microphone.
- Speak in your normal voice without shouting.

Initiating a Skype for Business Conference Call

When registered with Skype for Business, you can initiate a Skype for Business conference calls on VVX Business Media Phone.

Initiate a Skype for Business Conference

On VVX Business Media Phone, you can initiate a Skype for Business conference call, add and invite contacts to a conference call, and manage up to 24 conference calls.

You can only select one contact at a time to add to the conference call.

Procedure

1. Press **Meet Now > Invite**.
2. Enter a contact's number or select a contact from **Contacts** or **Recent Calls** and select **Dial**.
The contact is added to the call after answering.
3. Select **Invite** to add additional contacts to the conference call.

Initiate a Conference Call during a Skype for Business Call

During a Skype for Business call, you can add contacts to the call to initiate a conference call.

Note: You cannot initiate a Skype for Business conference call with video on VVX phones. If you are in an active video call when you initiate a conference call, the video call ends, and an audio-only conference call is established.

Procedure

1. Press **Conference** and select a contact.
2. Press **Invite** to add additional contacts to the conference call.

Initiating a Group Conference Call

You can initiate a Skype for Business conference call with all the contacts in a group on your phone or in the Skype for Business client.

Initiate a Group Conference Call

You can initiate conference call with a group of Skype for Business contacts on VVX Business Media Phone.

Procedure

1. Navigate to **Contacts** and select **Groups**.
2. On the **Groups** screen, select a group.
3. Select **Dial All**.
4. Choose **Yes** to confirm that you want to dial all contacts in the group.
Each contact in the group is called one at a time.

Initiate a Group Conference Call with a Distribution List

You can initiate a conference call with all the members of a distribution list on your phone.

Procedure

1. Press **Contacts** and select **Groups**.
2. On the **Groups** screen, select a distribution list, then select **Expand > Dial All**.

3. Press **Yes** to confirm that you want to dial all members in the list.

Each member in the distribution list is called one at a time.

Related Links

[Search for Skype for Business Distribution Lists](#) on page 80

Add Contacts to a Skype for Business Conference Call

During a conference call, any participant can invite additional contacts to the call.

Procedure

1. During a conference call, select **Invite**.
2. Select a contact to join the meeting.
An alert tone is played when the contact has joined the conference.

Send Contacts Active Conference Information

If you are a conference participant, you can send the conference dial-in number and PIN to contacts you want to join the call. You can view the conference contact information during an active conference call.

When a contact dials into a conference using the conference dial-in number and PIN, the contact is added to the conference call immediately unless the conference call is locked. When the conference call is locked, the contact must wait for the conference presenter to admit them to the call.

Procedure

1. During an active conference call, press **Conf.Opts**.
The dial-in number and PIN for the conference is displayed.
2. Copy the information and send it to the contacts you want to join the conference.

Related Links

[Lock and Unlock a Conference Call](#) on page 57

Viewing a List of Skype for Business Conference Participants

When you initiate or join a conference call, the conference participants automatically display in a Roster.

The list only displays participants in the conference call; it does not display any calls on hold, as shown next.

Roster of Skype for Business Conference Participants

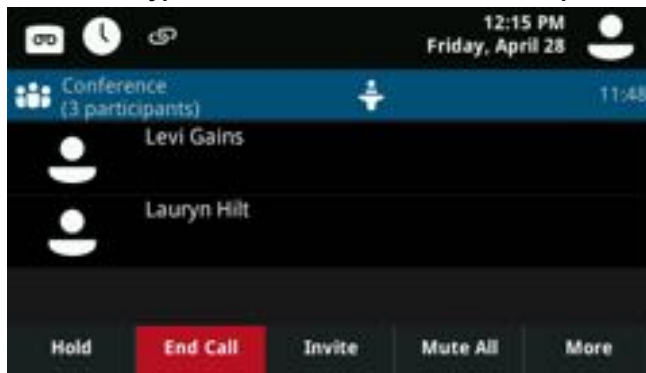

Exit the Roster

When you exit the Roster, the conference call displays on the Calls screen with the number of conference participants, but you cannot view the list of conference participants.

Procedure

1. Press **Close**.

Return to the Roster

Return to the Roster at any time during an active conference to view a list of current conference participants.

Procedure

1. Press **Roster**.

Managing Skype for Business Conference Participants

When you initiate a conference call, you and all conference participants are listed as presenters. Conference participants with the Presenter icon  next to their names are presenters and can manage conference participants.

As a presenter, you can manage call participants in the following ways:

- Mute all participants or individual participants.
- Remove participants from the conference call.
- Demote a presenter to an attendee or promote an attendee to presenter.
- Enable or disable conference announcements.
- Lock or unlock a conference.

These options do not display for attendees.

Muting Conference Participants

Only presenters can mute and unmute conference participants.

If a presenter mutes your audio, a notification is displayed on your device, and a Mute icon  is displayed next to each person who is muted. When a presenter mutes your audio in the Skype for Business client, it takes one second for the mute icon to display on your device.

You must wait for the presenter to unmute your audio before you can speak in the conference again.

Mute and Unmute All Conference Participants

Presenters can mute and unmute all conference participants at one time.

Procedure

1. Select **Mute All**.

A notification is displayed on the participants' phones informing them that the presenter has muted the audience.

2. Select **Unmute All** to enable participants to speak in the conference.

A notification is displayed on the participants' phones informing them that the presenter has unmuted the audience.

Mute and Unmute Individual Conference Participants

Presenters can choose to mute and unmute individual participants during conferences.

Procedure

1. Select a participant and select **Mute**.

A notification is displayed on the participant's phone informing him or her that the presenter has muted the participant.

2. Select the muted participant and select **Unmute**.

A notification is displayed on the participant's phone informing him or her that the presenter has unmuted the participant.

Demote or Promote Conference Participants

Presenters can promote conference participants from an attendee to a presenter, or demote conference participants from a presenter to an attendee.

Procedure

1. Select a conference participant and do one of the following:
 - Select **Host** to promote a participant to host.
 - Select **Attendee** to demote a host to attendee.

The participant is now an attendee or a host, who can manage conference participants.

Enable and Disable Conference Announcements

When enabled, announcements play whenever a host mutes or unmutes the audience, locks or unlocks the conference, and removes a conference participant, or when a new person joins the conference. Presenters can choose to enable or disable announcements during a Skype for Business conference call.

Procedure

1. During a conference call, do one of the following:
 - Select **Ena.Anc** to enable announcements
 - Select **Dis.Anc** to disable announcements.

Remove Conference Participants

A presenter can remove any participant, excluding the conference initiator, from the conference call.

Procedure

1. Select a participant and select **Remove**.
A notification is displayed on the participant's phone informing him or her that the host has removed them from the conference.

Lock and Unlock a Conference Call

Presenters can lock a conference call to prevent people from joining the conference call without approval.

When a conference is unlocked, anyone on the network can join a conference call automatically with the conference dial-in number and PIN. When the conference is locked, a contact must wait for the main presenter, the person who initiated the conference call, to admit the contact to the meeting.

Procedure

1. During an active conference, select **Lock**.
The conference is locked, and anyone that tries to join the call must be admitted by the main presenter.
2. When you're ready to enable people to join the conference, select **Unlock**.
The conference is unlocked, and anyone can join the conference call.

Related Links

[Send Contacts Active Conference Information](#) on page 54

Admit or Deny Participants to a Locked Conference Call

A contact that is trying to enter a locked conference call is displayed in the Roster with an alert icon  on the main host's phone, as shown next.

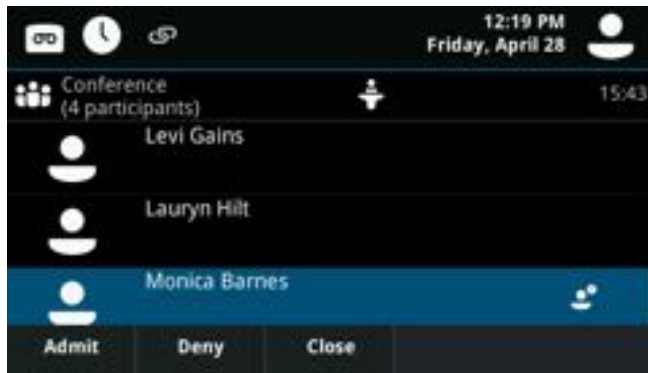

Procedure

1. Select the participant and do one of the following:
 - Select **Admit**.
 - Select **Deny**.

Shared Lines

Topics:

- [Shared Line Limitations](#)
- [Missed and Received Calls on Shared Lines](#)
- [Hold a Call Privately on a Shared Line](#)
- [Shared Line Appearance for Skype for Business](#)
- [Boss-Admin for Skype for Business](#)

All VVX business media phones support multiple and shared lines. Your administrator can customize your phone so that you have multiple shared lines enabled.

Shared Line Limitations

The following features are not available or have limitations on phones with shared lines:

- Forwarding an incoming call is not available.
- Enabling Do Not Disturb on shared lines disables ringing only, and a visual notification of the call is displayed with the option to answer the call.

Missed and Received Calls on Shared Lines

When you have an incoming call on a shared line, which none of the phones answer, the call is displayed in the Missed Calls list on all the phones. If you have an incoming call on a shared line and you or any of the other phones answer the call, the call is not logged as missed on any phone.

Your administrator can configure the phones so that if you have an incoming call on a shared line and one phone answers, the other phones log the call as a received call. That way, if another phone on a shared line answers an incoming call, you can still view the call information from your phone's call lists even if you did not answer the call.

Related Links

[View Recent Calls](#) on page 72

Hold a Call Privately on a Shared Line

When you place a call on hold on a shared line, all of the phones registered with that line are notified of the call's held status. You can hold a call privately on a shared line using the Private Hold feature, which places the call on hold and displays the line as busy on the other phones on the shared line. Contact your system administrator to find out if this feature is available on your phone.

When the Private Hold feature is enabled, the Pvt Hold soft key is displayed, and you can hold a call privately, transfer a call, or initiate a conference call without notifying others on the shared line of the call's held state.

Procedure

1. During a call, press **More > Pvt Hold**.

The call is held on your phone, and the line shows as busy on the other shared line users' phones.

When you hold a call privately, other users on the shared line cannot resume or pick up the call. However, users on the shared line can barge in on privately held calls. In order to allow other users to resume the call, you have to publicly hold the call by pressing the Hold key or soft key.

When Private Hold is enabled, you can also transfer a call or initiate a conference call without the other shared line users being notified of the call's status. When you press the Transfer or Conference soft key on the shared line, the call is held privately. If you press Hold before you transfer a call or initiate a conference, the other users on the shared line are notified of the call's held status.

Related Links

[Conference Calls](#) on page 52

[Transferring Calls](#) on page 44

Shared Line Appearance for Skype for Business

When your phone is registered with the Skype for Business Server, you can use the Shared Line Appearance (SLA) feature to share a single line with other contacts as a member of a group. System administrators assign members to SLA groups.

Any SLA group member can place, answer, hold, or resume calls on the line, and all group members can view the status of a call on the shared line on their phones. Each line supports up to 24 call appearances.

Only one call at a time can be active on the shared line appearance. If a call is placed to the shared line with an active call in place, the incoming call is sent to another shared line.

This feature is not supported on VVX 201 phones. Check with your system administrator to find out if this feature is available on your phone.

Shared Line Appearance Limitations

The following features are not available or have limitations on lines for secondary SLA group members:

- Outgoing calls are not supported.
- Enabling and using Better Together is not supported.
- Conference calling is not available.
- Parking calls is not supported.

Answering SLA Calls

Any incoming call to the shared line rings on all group members' phones simultaneously, the call is displayed on all members' screens, and a green LED light flashes on the line key.

Any group member can respond to an incoming call to the shared line. When a group member answers an incoming call, the line key's LED indicator on all phones changes to a steady red light to indicate the call was answered. Members can also view the status of a call on the shared line by pressing and holding the corresponding line key for one second. The call's status displays for five seconds.

Resume Held SLA Calls

Any SLA member can resume a held call on the shared line. When an active call is placed on hold on the shared line, all group members are notified of the call's new status by a flashing red LED light on the line key on all members' phones, if enabled by your system administrator.

When a held call is resumed by another SLA member, the other group members are notified of the call's new status with a steady red LED light on the line key on the members' phone.

Procedure

1. Select the corresponding line key and lift the handset.

Boss-Admin for Skype for Business

When your phone is registered with the Polycom with Skype for Business server, you can use the Boss-Admin feature to manage shared lines. The Boss-Admin feature enables you to manage phones on your network and see when there is an answered call, when a call is on hold, or when a call has ended on a boss or delegate line. A boss can assign delegates, and delegates can manage calls on behalf of the boss's line.

Assign Delegates

You can assign up to 25 delegates to your line using your Skype for Business client; however, you cannot assign yourself as a delegate to a boss's line. You can have delegates and be a delegate for another boss's line, and you can assign your bosses as delegates for your line.

Delegates can be assigned to up to 15 bosses, depending on the number of line keys available on their VVX phone. For example, for VVX 300 series phones, a delegate can be assigned to up to five bosses.

If a VVX Expansion Module is connected to the phone, any additional bosses assigned to the delegate display on the expansion module. If all available line keys have been assigned to boss contacts and an expansion module is not attached to the phone, additional bosses or contacts are not shown on the phone's screen.

Procedure

1. In your Skype for Business client, click  and select **Tools > Call Forwarding Settings**.
2. Select **Simultaneously Ring > My Delegates**, as shown next.

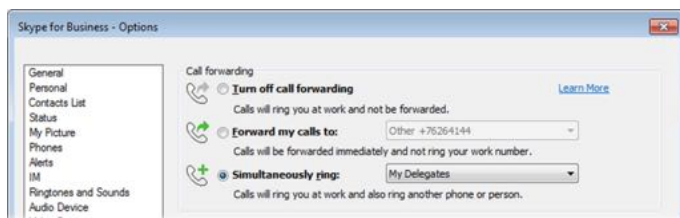

3. In the **Call Forwarding - Delegates** dialog box, click **Add** to add contacts as delegates for your calls.
4. In the **Choose a Delegate** dialog box, select the contact you want to add as a delegate and click **Ok**.

The contacts you add as delegates display in the **Call Forwarding - Delegates** dialog box, shown next.

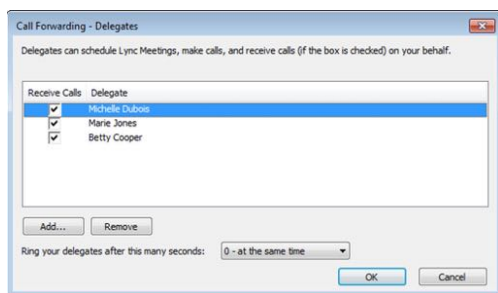

5. Click **OK** when you have finished assigning contacts as delegates.

Simultaneous ringing is enabled for all assigned delegates. If the boss's line receives an incoming call, both the boss and delegate's phones ring.

You can choose to change when your delegates' phones ring in the **Call Forwarding - Delegates** dialog box.

When you assign delegates to your line, your phone displays a notification that you have added a contact as a delegate, and a scrolling message "Simultaneous Ringing is activated" is displayed in the status bar.

When you are added as a delegate, a notification is displayed on your phone and in the Skype for Business client, and the boss icon  is displayed on the boss's line. The boss icon changes color to reflect the boss's presence status.

Related Links

[Forward Calls to Delegates](#) on page 51

[Change the Privacy Relationship for a Contact](#) on page 89

View the Delegates Group

Your delegates are automatically added to the Delegates group on your phone and in the Skype for Business client.

Procedure

1. Navigate to **Contacts > Groups > Delegates**.
All assigned delegates are displayed in order by last name.

View the Boss Group

You can view the contacts for which you are assigned as a delegate in the group People I Manage Calls For on your phone and in the Skype for Business client.

Procedure

1. Navigate to **Contacts > Groups > People I Manage Calls For**.
All assigned bosses are displayed in order by last name.

Set a Ringtone for Boss Calls

As a delegate, you can set a distinct ringtone for incoming calls on each of your assigned bosses' lines.

Procedure

1. Navigate to **Settings > Basic > Ring Type > Boss Ring Type**.
2. Select a boss and select a ring tone.

Edit the Delegates Group

You cannot edit the Delegates group on your phone. If you want to add or remove delegates, you need to edit the Delegates group in your Skype for Business client.

Procedure

1. In your Skype for Business client, click  and select **Tools > Call Forwarding Settings**.
2. Select **Edit my delegate members**, as shown next.

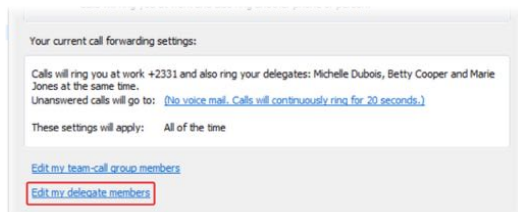

3. Do one of the following:
 - Select **Add** to add delegates.
 - Select a delegate and click **Remove** to delete the delegate from the group.

Delegates removed from the Delegates group can no longer monitor call activity on a boss's line.

Managing Calls on the Boss's Line

A boss can monitor calls on the delegate's line, and delegates can place, answer, hold, or transfer calls on behalf of the boss's line.

Respond to Incoming Boss Calls

When a call is placed to the boss's line, the call is displayed on the boss and delegate's phones. As a delegate, you can answer an incoming call on a boss's line, reject the call, or forward the call directly to the boss's voicemail.

If an incoming call for a boss is answered by a delegate or the boss answers the incoming call, a notification is displayed on the boss and delegate's phones.

Procedure

1. Do one of the following:

- Select **Answer**.
- Select **Dismiss** or **Ignore**.
- Select **Boss VM**.

Viewing Call Status on the Boss's Line

A boss and delegate can both view the status of any call on the other's phone. Bosses can see when a delegate answers or holds a call, which delegate answered the call, and the call information of the caller. Delegates can see when a boss is in an active call or has placed a call on hold. Bosses and delegates can also resume calls held on the other's line.

When there is an active call on the boss's line, for VVX 500/501 and 600/601 phones, a solid red bar is displayed on the boss's line key on the boss and delegates' phones. For 201, VVX 300 series, and 400 series phones, a steady red LED light on the boss's line key indicates there is an active call on the boss's line.

The next figure displays a call on the boss's line on a VVX 500/501 phone.

Call on the boss's line on a VVX 500/501 phone

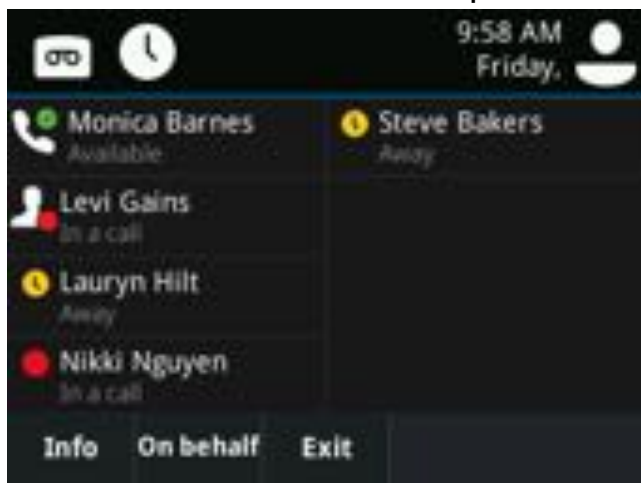

View Held Boss Calls

Bosses and delegates can both view held calls on the boss's line.

A flashing red bar or LED light indicates that a call is on hold on a boss's line.

Procedure

1. Press and hold the boss's line key.

Resume Held Boss Calls

Any assigned delegate can resume held calls on the boss's line.

Procedure

1. Press and hold the boss's line key.
2. Select the call and select **Pickup**.

Transferring Boss Calls

After a delegate answers a delegation call, the delegate can transfer the call to the boss's phone using the Safe Transfer feature, or transfer the call directly to the boss's voicemail if the boss is unavailable.

Transfer a Boss Call

After a delegate answers a delegation call, the delegate can transfer the call to the boss's phone using Safe Transfer, which enables the delegate to transfer the call to the boss's phone and prevent the call from going to voicemail if the boss does not answer the call.

Procedure

1. During a delegation call, press **More > Safe Xfer** .

The call is transferred to the boss's phone.

Resume a Transferred Boss Call

If the boss is not available to answer the transferred call, the call is returned to the delegate's phone.

When the transferred call is returned, the phone displays a notification stating that the call was not answered, and a tone plays on the delegate's phone.

After the call is returned, the delegate can resume the call and either try the Safe Transfer again or transfer the call to the boss's voicemail.

Procedure

1. Select the returned call and select **Resume**.

Transfer a Call to a Boss's Voicemail

If a boss is unavailable to take calls, delegates can transfer the calls directly to a boss's voicemail.

Procedure

1. During a delegation call, press **Boss VM**.

Place a Call on Behalf of a Boss

As a delegate, you can make calls on behalf of your assigned boss's lines.

When a call is made on behalf of the boss's line, a solid red bar is displayed on the line key on the boss's phone.

Procedure

1. Press and hold the boss's line key.
2. Select **On behalf**.
3. Select a contact, then select **Dial** or tap .

The delegate and third-party phones display a notification indicating that a delegate is calling on behalf of a boss.

Join Conference Calls for a Boss

You can join an incoming conference call on behalf of a boss's line and add the boss to the conference call.

Procedure

1. Press the **Conference** soft key.
2. Dial the boss's number or select the contact.
3. After the call is answered, press the **Conference** soft key.
4. After you have connected the boss's line to the conference call, press **End Call** to leave the conference call.

Recording Audio Calls

Topics:

- [Guidelines when Recording Calls](#)
- [Record a Call](#)
- [Manage a Call while Recording](#)
- [Pause a Recording](#)
- [Resume a Recording](#)
- [Stop Recording](#)
- [Record a Conference Call](#)
- [Browse Recorded Calls](#)
- [Play a Recorded Call](#)
- [Pause and Resume Played Recordings](#)
- [Stop Playing a Recording](#)
- [Rename a Recording](#)
- [Delete a Recording](#)

On VVX 401/411, 500/501, and 600/601 phones, you can record audio calls onto a USB flash drive connected to your phone. Recordings are stored as .wav files on the USB flash drive, and you can record up to four hours in one file. For a list of supported USB flash drives to record phone audio, see *Technical Bulletin 38084: Supported USB Devices* on [Polycom Support](#).

Note: To attach a USB flash drive, see the Quick Start Guide for your VVX phone on your phone's support page on [Polycom Voice Support](#).

Note: If your phone does not detect the USB flash drive when you attach it to the phone, the USB port may be disabled. Contact your system administrator for assistance.

Guidelines when Recording Calls

The following are a list of guidelines to follow when recording audio calls:

- Inform contacts when you are recording a call.
- Make sure you mute your audio when you are placed on hold while recording the call. When you place a call on hold while recording, the recording pauses. However, when another person places you on hold, the recording continues.
- During an active call, pause your recording before answering incoming calls. All incoming calls you answer after you start recording are also recorded in the same file. For example, on June 22, 2012, at 11:22 a.m., you answer a call from person A. During your call with person A, you answer calls from person B and person C. All three calls are recorded in the same file.

Record a Call

You can record all active audio calls on the phone. You cannot record calls when there are no connected calls, when you place a new call to transfer a call or initiate a conference, or when you have an incoming call.

Make sure to inform your contacts on the call before you begin recording.

Note that some tones made on your contact's phone are recorded. When you mute the microphone while recording, your audio is muted and only other participants' audio in the call are recorded.

Procedure

1. During an active call, select **Record > Start**.
The message "Recording in progress" is displayed in the status bar.

Manage a Call while Recording

You can hold, end, transfer, or set up a conference call while you record, or while a recording is paused.

Procedure

1. During a recording, select **Back** and choose a task to perform.
2. Select **Record** to view the Recording soft keys again.

Pause a Recording

You can pause a recording during a call at any time while the call is active.

Procedure

1. Select **Pause**.
The message "Recording Paused" is displayed in the status bar.

Resume a Recording

When you resume a recording after pausing, the recording continues within the same file.

Procedure

1. Select **Resume**.

Stop Recording

You can choose to stop recording a call before the call ends. The recording also stops when the active call ends, no matter who ended the call.

Caution: Do not remove the USB flash drive while recording. The file being recorded will be incomplete and cannot be played back later. When you remove the USB flash drive while recording, you can also damage the flash drive.

Procedure

1. Do one of the following:
 - Select **Stop**.
 - Select **Back > End Call**.

When you stop recording, the USB icon is displayed in the status bar.

Record a Conference Call

You can record a conference call in the same way as an active call with the following exceptions:

- All conference call participants are recorded. When a conference participant mutes his or her audio, that participant is not recorded.
- When you place a conference call on hold, the recording pauses. You can place or answer other calls, which are recorded in the same file. When you resume the conference call, the recording resumes.

Procedure

1. During an active conference call, select **Record > Start**.
The message “Recording in progress” is displayed in the status bar.

Browse Recorded Calls

On a VVX Business Media Phone, you can browse recorded files stored on the USB drive.

Procedure

1. Navigate to **Settings > Features > Removable Storage Media > Browse Recordings**.
A list of recordings display.

Play a Recorded Call

You can play back calls that you recorded on a USB drive on a VVX Business Media Phone.

If the handset is off-hook when you play a recording, the audio plays through the handset. If the handset is on-hook when you play a recording, the audio plays through the speaker.

Note: You cannot open and play recordings when you are in an active call or if you're recording a call. If you try to, a message indicating that the action was canceled is displayed. Place the call on hold before playing the recordings. The recording stops playing when you resume the call.

Procedure

1. Navigate to **Settings > Features > Removable Storage Media > Browse Recordings**.
A list of recordings display.
2. Select a recording.
3. Select **Open > Play**.
The length of the recording and a progress bar is displayed as the recording plays.

Pause and Resume Played Recordings

While playing a recording, you can pause the recording, perform another task on the phone, and resume the recording at any time.

When you receive an incoming call while playing a recording, the recording is paused automatically. If you do not answer or reject the incoming call, the recording remains paused until you select Resume.

Procedure

1. While the recording plays, select **Pause**.
2. Select **Resume** to continue playing the recording.

Stop Playing a Recording

When you are finished listening to a recording, you can stop playing it by exiting the recording.

Procedure

1. Select **Exit**.

Rename a Recording

By default, recordings are labeled with the date of the recording. You can rename recordings to provide them with more meaningful names.

Procedure

1. Navigate to **Settings > Features > Removable Storage Media > Browse Recordings**.
A list of recordings display.
2. Select a recording.
3. Select **Rename**, update the file name, and select **OK**.

Delete a Recording

When you have played a recording or need additional space on your USB drive, you can delete recordings from the phone.

Procedure

1. Navigate to **Settings > Features > Removable Storage Media > Browse Recordings**.
A list of recordings display.
2. Select a recording.
3. Select **Delete**.

Call Lists, Distribution Lists, and Directories

Topics:

- [Recent Calls](#)
- [Contact Directory](#)
- [Corporate Directory](#)
- [Searching the Skype for Business and Outlook Directories](#)
- [Managing Skype for Business Distribution Lists](#)

All VVX business media phones support a Recent Calls list, a Contact Directory and a Corporate Directory. The phones can also support a Skype for Business Directory and Microsoft Distribution Lists, if enabled by your system administrator.

Note: The generic_prod_term may not support all of the features described in this section. Check with your system administrator to find out which features are available.

Recent Calls

When the phone is registered with the Skype for Business Server, you can view the last 99 Skype for Business calls in the Recent Calls list on the phone, in the Skype for Business client on the Conversations tab, or in Microsoft® Outlook® in the Conversation History folder.

You can perform the following tasks from the Recent Calls list:

- Sort, order, and filter calls. By default, the list displays all call types with the most recent call displaying first.
- Remove calls from the list.
- Select a call record to view call details.
- Select a call record to automatically call a contact.

View Recent Calls

In the Recent Calls list, you can view a list of up to 100 missed, received, and placed call entries.

Procedure

1. Do one of the following:
 - Navigate to **Directories > Recent Calls**.
 - On VVX 500/501 and 600/601 phones, tap  in the status bar.

Related Links

[Missed and Received Calls on Shared Lines](#) on page 59

Sort Recent Call Entries

You can customize the Recent Calls list to view calls by call type, time, and call name.

When you sort calls by the time of the call, you can order them in ascending (oldest call first) or descending (most recent call first) order. When you sort calls by name, you can order them in ascending (alphabetical) or descending (reverse-alphabetical) order.

Procedure

1. Select **Sort** or tap .
2. Under **Sort**, choose **Time** or **Name**.
3. Under **Order**, choose **Ascending** or **Descending**.

Sort Entries by Call Type

When you filter calls, you can choose to display only missed, received, or placed calls. Or, you can choose to display all call types (the default).

Note: You cannot save your filtered call list results. If you filter your Recent Calls list so that only a certain call type displays, the next time you display the list, all call types display in the default filter.



Procedure

1. Select **Type** or tap .
2. Choose **Missed Calls**, **Received Calls**, or **Placed Calls**.

Edit a Recent Call Entry

You can edit a contact's phone number stored in your Recent Calls list before returning the contact's call.

Procedure

1. Select **Info** or tap  next to a call record.
2. Select **Edit** or tap .
3. Edit the number, and select **Dial** or tap .

Delete a Recent Call Entry

You can delete any recent call entry from the Recent Calls list.

If you delete or move call entries on the phone, if enabled, the changes are made on the phone only. If you delete call entries in the Skype for Business client, the changes are made on the phone and in the Skype for Business client.

Procedure

1. Select **Info** or tap  next to a call record.

2. Select **Delete** or tap .

Save a Recent Call Entry

You can save a recent call entry to the Contact Directory.

Procedure

1. Select **Info** or tap  next to a call record.
2. From the **Call Details** screen, select **Save**.
If the person is already in your Contact Directory, but is not a favorite, **Add to Favorites** is displayed.

Related Links

[Contact Directory](#) on page 74

View Call Details

In the Recent Calls list, you can view call details, edit call details before calling a contact, save a contact to your directory, and delete call entries.

Procedure

1. Select **Info** or tap  next to a call record.

Contact Directory

You can store a large number of contacts in your phone's Contact Directory, as well as add additional contacts, view and update a contact's information, and delete contacts from the directory.

Contact your administrator for the exact number of contacts you can store in the Contact Directory for your phone model.

Note: If you can not add or edit contacts in the Contact Directory, your system administrator has set the directory as read-only. Contact your system administrator for assistance making any changes to the contacts stored in the directory.

Related Links

[Save a Recent Call Entry](#) on page 74

[Save Skype for Business Contacts to the Contact Directory](#) on page 78

[Save Outlook Contacts to the Contact Directory](#) on page 79

[Add Corporate Directory Contacts to the Contact Directory](#) on page 77

Search for a Contact in the Contact Directory

In the Contact Directory, you can search for your desired contact.

Procedure

1. Navigate to **Directories > Contact Directory**.

2. In the **Contact Directory**, select **Search**.
3. In the search field, enter your search criteria and select **Submit**.

Add a Contact to the Contact Directory

When you add a contact to your Contact directory, you can choose how much information you want to enter for your contact. You are required to only enter a contact number for each new contact.

The following is a list of information you can enter for each contact:

- First and Last Name—The name of your contact
- Contact—Your contact's phone number
- Job Title—Your contact's position
- Email—Your contact's personal or work email address
- Favorite Index—An index number that displays in your Favorites list
- Label—A label or title for your contact

Note: If your phone does not display all of these contact fields, contact your system administrator. The only required field in the Contact Directory is the Contact field, which includes the contact's phone number.

Procedure

1. Navigate to **Directories > Contact Directory**.
2. In the **Contact Directory**, select **Add** or tap **+**.
3. From the **Add Contact** screen, enter your contact's information in the available fields.
You are required to only enter a number in the **Contact** field when adding a new contact to the directory. You can choose to enter additionally information.
4. Select **Save**.

View Contact Information

From your Contact Directory, you can view information, such as name and phone number, for any contacts saved to the directory. Additional information, such as a job title, label, or email address, can also display.

Procedure

1. Navigate to **Directories > Contact Directory**.
2. From the **Contact Directory**, select a contact.

Update a Contact's Information

After you add a contact to your Contact Directory, you can update the contact's information.

Procedure

1. From the **Contact Directory**, select a contact.

2. From the **Contact Information** screen, do one of the following:
 - Select **Edit**.
 - Select **Info > Edit**.
 - Tap .
3. From the **Edit Contact** screen, update the contact's information.
4. Select **Save**.

Delete a Contact from the Contact Directory

You can delete any contact from the Contact Directory.

Procedure

1. Navigate to **Directories > Contact Directory**.
2. From the **Contact Directory**, select a contact.
3. From the **Contact Information** screen, do one of the following:
 - Select **Delete**.
 - Tap .
 - Select **Info > Delete**.

A confirmation message is displayed, confirming that you want to delete the contact.

4. Select **Yes** to delete the contact.

Corporate Directory

Your system administrator can set up your VVX Business Media Phone so that you can access a Corporate Directory. However, you cannot update the Corporate Directory, and your administrator determines which contacts you can see. Check with your system administrator to find out if this feature is available.

Searching the Corporate Directory

In the Corporate Directory, you can perform a quick or advanced contact search.

Perform a Quick Search of the Corporate Directory

A quick search enables you to search for contacts using either their first name or last name.

Procedure

1. Navigate to **Directory > Corporate Directory**.
2. In the search field, enter your search criteria and select **Submit**.
3. Select a contact and select **View** to view the contact's information.

Perform an Advanced Search of the Corporate Directory

An advanced search enables you to choose to search for contacts by first name, last name, or phone number.

Procedure

1. Navigate to **Directory > Corporate Directory**.
2. In the **Corporate Directory**, select **AdvFind**.
3. In the search field, enter your search criteria and select **Submit**.
4. Select a contact and select **View** to view the contact's information.

Save Corporate Directory Search Results

You can save your last search results so that the next time you view the Corporate Directory, the results of your last search is displayed.

Procedure

1. Navigate to **Settings > Basic > Preference > Corporate Directory > View Persistency**.
2. From the **View Persistency** screen, select **Enabled**.
Each time you view the Corporate Directory, your last search results automatically display.

Clear Corporate Directory Search Results

After you search for a contact, you can clear your search results and start a new search.

Procedure

1. On the **Search** screen, select **Clear**.

Add Corporate Directory Contacts to the Contact Directory

You can add contacts in the Corporate Directory to the Contact Directory.

When you save a Corporate Directory contact to the Contact Directory, the first name, last name, and phone number of the contact are automatically saved to the directory. You can add additional contact information after the contact is saved to the directory.

Procedure

1. In the **Corporate Directory**, search for a contact.
2. From the search results, select the contact and select **View**.
3. Select **Save**.
4. Enter any additional contact information and select **Save**.

Related Links

[Contact Directory](#) on page 74

Searching the Skype for Business and Outlook Directories

The Microsoft Skype for Business Address Book Service (ABS) enables you to search for Skype for Business and Microsoft Outlook contacts in the Skype for Business Directory or Outlook Directory, view a contact's information and presence status, call contacts from the directory search results, and save contacts to your Contact Directory.

Search the Skype for Business Directory

You can search for contacts in the Skype for Business Directory on your phone.

Procedure

1. Select **Search** on the Home screen or navigate to **Directories > Skype Directory**.

A search screen is displayed.

2. Enter your contact's name.

If you're using the onscreen keyboard, tap ✓.

The Skype for Business Directory displays your contact and similar contacts as you type your contact's name.

Saving Contacts from the Skype for Business Directory

You can add contacts from the Skype for Business Directory to your Skype for Business Contacts list or the Contact Directory.

Save Contacts to Skype for Business Contacts

When you save a contact to your Skype for Business Contacts list, the contact's name and email address are saved.

Procedure

1. Search for your contact.
2. Select your contact and select **Add to Contacts**.

The contact is saved to your Skype for Business Contacts list.

Save Skype for Business Contacts to the Contact Directory

The first name, last name, and phone number of the contact are saved to the Contact Directory. You can go to the Contact Directory to see if the contact was saved correctly and to add additional contact information.

Procedure

1. Search for your contact.
2. Select your contact and select **View**.
3. In the **Contact Information** screen, select **Save**.

Related Links

[Contact Directory](#) on page 74

Search the Outlook Directory

You can search for Microsoft Outlook contacts on your phone.

Procedure

1. Navigate to **Directories > Outlook Search**.
2. Enter your contact's first or last name.

If you're using the onscreen keyboard, tap ✓ after you have entered your contact's information.

Your contact and similar contacts are displayed automatically as you type your contact's information.

Save Outlook Contacts to the Contact Directory

You can save Outlook contacts to the Contact Directory on your phone.

The first name, last name, and phone number of the contact are saved to the Contact Directory. You can go to the Contact Directory to see if the contact was saved correctly and to add additional contact information.

Procedure

1. Search for your contact.
2. Select your contact.
3. Select **Add to Contacts**.

If you do not see the Add to Contacts soft key, select the **More** soft key.

Related Links

[Contact Directory](#) on page 74

Managing Skype for Business Distribution Lists

When you are signed into Skype for Business on your phone, you can search for and manage Microsoft distribution lists (DL) from your phone.

You can perform the following tasks regarding distribution lists:

- Search for distribution lists
- Add or delete a distribution list
- View information for distribution lists and members of a list

Maximum Number of Distribution List Members

The following table indicates the maximum number of distribution list (DL) members that display on each phone model after you expand a DL.

Maximum Number of Distribution List Members

| Model | Maximum Number of Members |
|---------------------------------------|---------------------------|
| VVX 201 | 10 |
| VVX 300/310 | 50 |
| VVX 301/311 | 50 |
| VVX 400/410 | 50 |
| VVX 401/411 | 50 |
| VVX 500/501 | 50 |
| VVX 500/510 | 50 |
| VVX 600/601 | 50 |
| VVX Expansion Modules (color display) | 100 |

Search for Skype for Business Distribution Lists

The Skype for Business Address Book Service (ABS) enables you to search for Skype for Business and Microsoft Outlook distribution lists in the Skype for Business Directory on the phone.

Procedure

- Do one of the following:
 - Select **Search** on the Home screen or navigate to **Directories > Contacts > Search**.
 - Navigate to **Directories > Skype Directory**.
- Enter the name of the distribution list starting with DL-, or just enter a few letters in the distribution list name.

If you're using the onscreen keyboard, tap ✓.

Your search results display with similar distribution lists as you type.

Related Links

[Call a Member of a Distribution List](#) on page 38

[Initiate a Group Conference Call with a Distribution List](#) on page 53

Save a Distribution List to the Contacts List

You can add a distribution list (DL) or a search result to your Contacts. Contacts you add are available in both the phone and Skype for Business client.

Procedure

- Navigate to **Directories > Contacts > Search**, then search for your DL.
- Select your DL, then press **Add to contacts**.

The distribution list is added to the Groups list on the phone and in the Skype for Business client.

3. Navigate to **Directories > Contacts > Groups**, and verify that the DL was added to the Groups list.

View Contact Information for a Distribution List

You can view contact information, including name and email address, for any distribution list (DL) from your phone.

Procedure

1. Navigate to **Directories > Contacts > Group**, then select a DL.
2. Select **Info**.

View Contact Information for a Member of a Distribution List

You can view the contact information for members of a distribution list (DL) from the phone. The phone displays the name, presence status, email address, and phone number for each DL member.

Procedure

1. Navigate to **Directories > Contacts > Group**, then select a DL.
2. Select **Expand**, select a DL member, then select **Info**.

Delete a Distribution List

You can delete a distribution list from the phone. Distribution lists you delete are removed from both the phone and in the Skype for Business client.

Procedure

1. Navigate to **Directories > Contacts > Group**, then select a DL.
2. Select **Delete**, then confirm deletion.

The DL is removed from the phone and in the Skype for Business client.

Favorites and Contact Lists

Topics:

- [Managing Favorites](#)
- [Skype for Business Contacts](#)

On your VVX phone, you can add contacts as favorites and view and manage Skype for Business contacts.

Note: Your phone may not support all of the features described in this section. Check with your system administrator to find out which features are available on your phone.

Managing Favorites

Favorites are the contacts in your Contact Directory that you will call most often. You can add contacts as favorites from the Contact Directory, designate an index number for favorites, view favorites on the Home or Lines screen depending on your phone, and delete favorites.

Add Favorites

Contacts that you add as favorites display on the Home screen , in the Lines screen , and in the Favorites list on all VVX phones. On all VVX phones, a star is displayed for contacts saved as favorites.

Procedure

1. Navigate to **Directories > Contact Directory**.
2. From your **Contact Directory**, select a contact.
3. Select **Add** or **Add to Favorites**.
A notification is displayed asking if you want to automatically accept the next available index number, or manually enter your own.
4. Select **Yes** to automatically accept an index number or select **Edit Index** to enter a unique index number.

You can enter a number up to 99 for VVX 201 phones or 9999 for all other VVX phones.

Related Links

[Assign Favorites to VVX Expansion Modules](#) on page 133

Viewing Favorites

You can view favorites in your Favorites list in the Directory or the New Call screen. Favorites display consecutively according to their index number. The contact with the lowest number is displayed first.

Related Links

[Reorder Favorites](#) on page 83

View Favorites

You can view favorites in the Favorites lists from the New Call screen.

Procedure

1. Select **New Call > Favorites**.

View Favorites on the Home Screen

On VVX 500/501 and 600/601, you can tap the phone line to view favorites from the Home screen. You cannot view favorites from the Home screen on VVX 201, 300 series, and 400 series phones.

Procedure

1. From the **Home** screen, tap the phone line.

View Favorites from the Lines Screen

You can view a list of favorites on the Lines screen on all VVX phones.

Procedure

1. From the **Home** screen, press .

Reorder Favorites

You can change the order in which your favorites display on the Home or Lines screen.

Procedure

1. From your **Contact Directory**, select a contact.
2. From the **Contact Information** screen, select **Edit** or tap .
3. From the **Edit Contact** screen, select **Favorite Index**, and enter a new favorite index number.
4. Select **Save**.

Related Links

[Viewing Favorites](#) on page 82

Delete Favorites

You can delete favorites to make room for new favorites.

Procedure

1. From your **Contact Directory**, select the contact.
2. From the **Contact Information** screen, select **Edit** or tap .
3. From the **Edit Contact** screen, select **Favorite Index**, and delete the favorite index number.
4. Select **Save**.

Tip: To quickly delete a contact, on the Lines screen, press and hold the favorite until the Contact Information screen is displayed. Select **Delete** or tap . The contact remains in your directory, but is no longer a favorite.

Skype for Business Contacts

You can add Skype for Business contacts from the Skype for Business directory to your contact list and call Skype for Business contacts on your phone.

Unified Contact Store

After your administrator unifies your contacts on the Skype for Business Server, you can access and manage your contacts from any application or device you are signed into with your Skype for Business account, including a VVX business media phone, Skype for Business client, Outlook, or Outlook Web Application.

When Unified Contact Store is enabled, you can add or delete contacts and distribution list or copy and move contacts across groups, and any changes made to your contacts is unified across all devices and applications. For example, if you delete a contact from your VVX phone, the contact is also deleted in the Skype for Business client.

Note: You can copy and move contacts across groups only in the Skype for Business client. Any contacts copied or moved across groups in the client are automatically updated on the phone. You cannot copy or move contacts across groups on the phone.

Add a Contact to Your Microsoft Skype for Business Contact List

Contacts you add to your Skype for Business client display alphabetically in the Skype for Business contact list on your phone until the maximum number of contacts is reached. See the following table for the maximum number of contacts you can add to your phone. Note that when you delete a Skype for Business contact from your phone, the contact is deleted from your Skype for Business client as well.

Maximum Number of Contacts Permitted

| Phone Models | Maximum Contacts |
|---|------------------|
| VVX 201, 300, 301, 310, 311, 400, 401, 410, and 411 | 100 |
| VVX 500, 501, 600, and 601 | 200 |

Procedure

1. Select **Contacts** or navigate to **Settings > Features > Presence > Contacts**.
2. Select **Add**, enter your contact's email address, and select **Submit**.

If you're using the onscreen keyboard, tap  then **Submit**.

Your contact is added to your Contact list.

View Skype for Business Favorites and Groups

You can view the Skype for Business contacts you save as favorites on the Lines screen. You can view presence information only for contacts you add as favorites in the Skype for Business client. If you add a Skype for Business contact as a favorite on your phone, presence information for that contact does not display.

Favorite Skype for Business contacts on the Lines screen



You can also view groups created in your Skype for Business client on your phone. However, you cannot create new groups, delete existing groups, or move contacts between groups on your phone.

Procedure

1. Select **Contacts > Groups** or navigate to **Settings > Features > Presence > Contacts > Groups**.

All your Skype for Business contact groups display.

Assign Skype for Business Contacts to Line Keys

When you are signed into Skype for Business on your VVX phone, you can assign Skype for Business contacts to a specific line on the phone or the VVX Expansion Module. You can choose to assign contacts to a line key from your Contacts list, or from searching for a contact in the Skype for Business Directory.

Procedure

1. Navigate to **Settings > Basic > Line Key Customization**.
2. Select **Phone Line Keys**.
3. Select a line key then select **Assign**.
4. Choose one of the following to assign your contact to the line key:
 - Select **Search** and enter your search criteria to find a contact in the Skype Directory.
 - Select **Contacts** to choose a contact from the Contacts list.
5. Select your contact and press **Assign**.

The contact is assigned to the selected line key.

Related Links

[Enable Line Key Customization](#) on page 110





[Assign Skype for Business Contacts to VVX Expansion Modules](#) on page 133

Skype for Business Contacts' Presence Information



You can view a contact's presence information on the Lines screen on your phone or in your Skype for Business client on your computer. Presence information includes your contact's availability and an activity description.





The following tables show the presence icons that display for Skype for Business contacts on supported VVX business media phones.

Presence Icons on VVX 400, 500, and 600 Series Phones







| Icons | Description |
|---|---|
|  | Available |
|  | Busy, In a Call, In a Meeting, In a Conference Call |
|  | Away, Be Right Back, Inactive, Off Work |
|  | Do Not Disturb, Presenting, In Presentation |
|  | Offline |
|  | Unknown |
|  | Out of Office |

Presence Icons on VVX 300 Series Phones

| Icons | Description |
|---|---|
|  | Available |
|  | Busy, In a Call, In a Meeting, In a Conference Call |

| | |
|---|---|
|  | Away, Be Right Back, Inactive, Off Work |
|  | Do Not Disturb, Presenting, In Presentation |
|  | Offline |
|  | Unknown |
|  | Blocked |

Presence Icons on VVX 201 Phones

| Icons | Description |
|---|---|
|  | Available |
|  | Busy, In a Call, In a Meeting, In a Conference Call |
|  | Away, Be Right Back, Inactive, Off Work |
|  | Do Not Disturb, Presenting, In Presentation |
|  | Offline |
|  | Unknown |

Blocked



Related Links

[Update Your Skype for Business Presence](#) on page 117

View Contact's Activity on VVX 201, 300, and 400 Phones

On VVX 201, 300 series, and 400 series phones, only a contact's presence status is displayed on the Lines screen. You can view your contact's activity description in the Contact Information screen.

Procedure

1. Press and hold the contact's line key for one second.

The **Contact Information** screen is displayed with your contact's presence status and activity description, as shown the next.

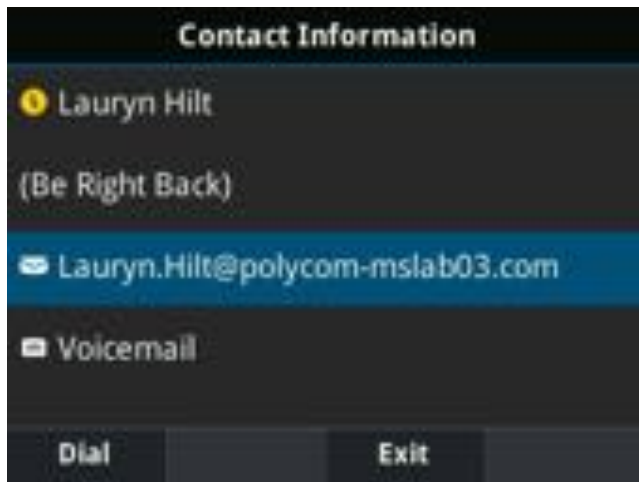

View Contact Information on the Lines Screen

You can view your contacts' presence and activity description on the Lines screen on VVX 500/501 and 600/601 phones. You can view additional information for your contact on the Contact Information screen.

Procedure

1. Press and hold a contact's line key for one second.

View the Skype for Business Contacts' Information

You can view contact information for each of your Skype for Business contacts on VVX Business Media Phone, and make calls directly to any of the available numbers for your contact, including directly to a contact's voicemail.

You can view the following detailed information for Skype for Business contacts, if depending on the privacy relationship:

- Name
- Presence Status
- Organization
- Email address
- Work number
- Mobile number
- Home number
- Voicemail

Procedure

1. Select the **Contact** soft key.
2. Select a contact and select **Info**.

The contact card is displayed with your contact's presence status and contact information.

Tip: You can quickly view contact information for a Skype for Business contact by pressing and holding a contact's line key.

Change the Privacy Relationship for a Contact

In order for you to view detailed information for a contact, that contact must change your privacy relationship to Friends and Family in the Skype for Business client. If your contact does not change your privacy relationship to Friends and Family, you can view the work number, email address, and voicemail only for that contact.

Procedure

1. In the Skype for Business client, select a contact, right-click, and select **Change Privacy Relationship**.
2. Click **Friends and Family**.

Your contact can now view all of your available contact information.

Note: You cannot change the privacy relationship for contacts assigned as a delegate for your line. Contacts you assign as delegates must maintain a privacy relationship of Workgroup. If you try to change the privacy relationship for a delegate, a notification is displayed in the Skype for Business client.

Related Links

[Assign Delegates](#) on page 61

Accessing, Sending, and Broadcasting Messages

Topics:

- [Access Skype for Business Voicemail Messages](#)
- [Managing Skype for Business Voicemail Messages](#)
- [Instant Messaging](#)
- [Broadcasting Messages with Group Paging](#)
- [Broadcasting Messages with Push to Talk](#)

You can access, send, and broadcast a variety of audio and written messages on VVX phones.

Note: Your phone may not support all of the features described in this section. Check with your system administrator to find out which features are available on your phone.

Access Skype for Business Voicemail Messages

You can view individual voicemail messages for Skype for Business calls on the phone. For each voicemail message, you can view the contact who left the message, the contact's presence status, and the status of the voicemail message.

Procedure

1. Press **Messages > Voicemail**.
A list of voicemail messages with status of each message displays.
2. Select a message and select **Play**.

Managing Skype for Business Voicemail Messages

From the Skype for Business Voicemail screen, you can call a contact, delete messages, or mark messages as read.

Call a Contact from Voicemail

After you listen to a contact's voicemail, you can call the contact from the Voicemail screen.

Procedure

1. Select a message and select **Call**.

Delete Voicemail Messages

After you listen to a message, you can delete the message.

Procedure

1. Select a message and select **Delete**.

Mark Message as Read

You can choose to mark unread messages that you do not want to listen to as read. Marking a message as read removes the message alert.

Procedure

1. Select a message and select **Mark As Read**.

Instant Messaging

You can send and receive instant messages using your phone. Instant messaging is an optional feature. Contact your system administrator to find out whether instant messaging is enabled on your phone.

Send Instant Messages

When you send a message, you can either select a message from a preset list of short messages, for example, “Call me” and “Can’t chat now”, or you can use the dial pad or onscreen keyboard to enter a custom message.

Procedure

1. From the **Home** screen, navigate to **Messages > Instant Message**.
The Instant Messages screen is displayed.
2. If you have multiple lines on your phone, select a line.
3. From the **Instant Messages** screen, select the **New** soft key.
4. Enter a contact’s phone number, URL, or IP address, and select **OK**.
The phone number, URL, or IP address you entered is displayed on the screen.
5. Do one of the following:
 - Press **Select** to choose a pre-scripted message from the **Message Select** screen.
 - Select **Edit** to compose a custom message, and enter your message.
6. Select **Send**.

Read Instant Messages

Instant messages display in the order they are received with the first message received displaying first.

Procedure

1. From the **Home** screen, navigate to **Messages > Instant Message**.
2. If you have multiple lines on your phone, select a line.
The first message received is displayed.

3. Select the **Next** or **Previous** soft key to read additional messages, if available.

Reply to Instant Messages

After you read an instant message on your phone, you can send a reply to the message.

Procedure

1. From the **Instant Messages** screen, select the **Reply** soft key.
2. Enter a message and select **Send**.

Delete Instant Messages

You can choose to delete older instant messages from your phone.

Procedure

1. Select a message and select the **Delete** soft key.

Broadcasting Messages with Group Paging

Group Paging enables you to make pages—one-way audio announcements—to contacts subscribed to a page group. Your administrator can enable your phone to operate in a broadcast mode called Group Paging mode. In this mode, you can broadcast one-way announcements to a specified group of phones, called a Paging Group.

Your system administrator can define up to 25 paging groups. Your system administrator can assign a label to each group to identify the phones in the group, such as All, HR Dept, Shipping Staff, or Executives.

Each group has one of the following priorities:

- **Normal**—By default, broadcasts sent to groups 1 to 23 are considered Normal broadcasts. By default, all phones are configured to receive broadcasts sent to group 1.
- **Priority**—By default, broadcasts sent to group 24 are considered Priority broadcasts. A Priority broadcast interrupts Normal broadcasts or active calls. All phones receive Priority broadcasts unless Do Not Disturb is enabled.
- **Emergency**—By default, broadcasts sent to group 25 are considered Emergency broadcasts. An Emergency broadcast interrupts Normal broadcasts, Priority broadcasts, and active calls and plays out at near maximum volume even if Do Not Disturb is enabled.

To send and receive pages, you need to subscribe to certain paging groups. By default, you are subscribed to paging groups 1, 24, and 25, and you can send and receive pages to those paging groups. Contact your system administrator to find out which paging group you are subscribed to.

Send a Group Page

When you send a group page, it is automatically sent to the default paging group, which is group 1. You cannot send a page while you are in an active call.

Procedure

1. From the Lines screen, select the **Paging** soft key.

2. From the **Paging Groups** screen, select the paging group to send the page to.
3. To begin a page, select **Page**.
Just before the page starts, you'll hear an alert tone, and then the page begins.
4. Begin speaking.
5. To end the page, select **End Page**.

Related Links

[Change the Default Paging Group](#) on page 94

Receiving Pages

You receive pages on the paging groups you are subscribed to as well as Group 24, Priority pages, and Group 25, Emergency pages. When you enable Do Not Disturb, you only receive Emergency pages. Non-emergency pages do not display or play on your phone.

How you receive a page depends on the priority of the page, whether you are in an active call, and whether your phone is set to receive a page during an active call. When you receive a page, the page is always played through the phone's speakerphone. You cannot play a page through your handset or headset.

When you enable Do Not Disturb on your phone, you receive only Emergency broadcasts. Non-emergency broadcasts do not display or play on your phone.

Related Links

[Update Paging Group Subscriptions](#) on page 94

Listen to a Page during an Active Call

How you handle a page when you are in an active call depends on the page priority and whether the phone is set up to receive a page during active calls.

The following occurs when you receive a page during a call:

- For Normal pages, the page immediately plays, and you hear audio from both the active call and the page.
- For Priority or Emergency page, the page immediately plays. You hear audio from the active call and the page.
- If the phone is not set up to receive Normal pages during active calls, the page is displayed as Pending.

Note: You adjust the volume of a Normal, non-emergency page while it plays, and the phone uses the adjusted volume for all subsequent non-emergency pages. However, only your system administrator can change the volume of an Emergency page.

Procedure

1. Do one of the following:
 - For pages that play automatically during a call, hold the call to hear only the page.
 - For Pending pages, select **Accept** or hold the call.

Receiving Pages When You're Not in an Active Call

When you receive a page and you are not in an active call, the page immediately plays, regardless of the paging priority.

While a page plays, you can:

- Hold the page.
- End the page. This ends the page at your phone only.
- Place a new call.

Group Paging Settings

This section provides information on changing your default paging group, updating page group subscriptions, and enabling pages to play during active calls.

Note: The features described in this section require access to the Basic settings menu on the phone. If your phone requires a password to access the Basic settings menu, contact your system administrator for assistance customizing your phone.

Change the Default Paging Group

The default paging group is group 1. You can change the default paging group to any group you want. If you change your default paging group, you are automatically subscribed to the group you selected.

Procedure

1. Navigate to **Settings >Basic > Preferences > Paging/PTT Configuration > Group Paging**.
2. From the **Group Paging Configuration** screen, select **Default Group**, and select a new paging group number.

When you press Paging, your phone sends pages using the new group.

Related Links

[Send a Group Page](#) on page 92

Update Paging Group Subscriptions

By default, you are subscribed to Paging Groups 1, 24, and 25. This means that you can send pages to and receive pages sent from these groups. You can change which groups you are subscribed to. However, you cannot disable your subscriptions to Paging Groups 24 and 25.

Procedure

1. Navigate to **Settings >Basic > Preferences > Paging/PTT Configuration > Group Paging**.
2. From the **Group Paging Configuration** screen, select **Group Subscriptions**.
3. From the **Group Subscriptions** screen, select the group you want to subscribe to, and select **Yes**.

Related Links

[Receiving Pages](#) on page 93

Enable Pages to Play during Active Calls

The Accept While Busy setting determines what happens when you are in a call and receive a page. This setting is disabled by default, and when disabled, the incoming page is held in a Pending state, it does not disrupt the call, and you cannot hear the page.

When you enable the Accept While Busy setting, a page interrupts calls and you hear the audio of the call and the page.

Procedure

1. Navigate to **Settings >Basic > Preferences > Paging/PTT Configuration > Group Paging**.
2. From the **Group Paging Configuration** screen, scroll to **Accept While Busy**, and enable or disable the setting.

Broadcasting Messages with Push to Talk

The Push-to-Talk (PTT) feature enables you to transmit messages and listen to replies much like a walkie-talkie.



Your system administrator sets up the feature, defines up to 25 channels for PTT mode, and assigns a label to each channel that easily identifies the channel, such as All, HR Dept, Shipping Staff, or Executives. By default, you are subscribed to Channels 1, 24, and 25. This means that you can send and receive PTT broadcasts on Channels 1, 24, and 25.

Each group or channel has one of the following priorities:

- *Normal* By default, broadcasts sent to channels 1 to 23 are considered Normal broadcasts. If two users begin a broadcast on the same group/channel at the same time, the phone with the lower serial number continues to transmit while the other phone enters the receiving state. By default, all phones are configured to receive broadcasts sent to channel 1.
- *Priority* By default, broadcasts sent to channel 24 are considered Priority broadcasts. A Priority broadcast interrupts Normal broadcasts or active calls. All phones receive Priority broadcasts unless Do Not Disturb is enabled. Phones play Priority broadcasts at the phone's current audio level.
- *Emergency* By default, broadcasts sent to channel 25 are considered Emergency broadcasts. An Emergency broadcast interrupts Normal broadcasts, Priority broadcasts, and active calls and plays out at near maximum volume even if Do Not Disturb is enabled.

Send a PTT Broadcast

You can choose a channel to broadcast on before you send a PTT broadcast, or you can hold the Talk soft key to immediately begin broadcasting on Channel 1, the default channel.

While you send a broadcast, you can pick up the handset, or press the Speakerphone  or Headset  key, and continue speaking. You can also press the Mute key  to mute your audio so that the people receiving your broadcast do not hear anything. This behavior is similar to a phone call.

Tip: To automatically send a PTT broadcast on the default channel, press and hold **Talk**. After the transmitting beep, begin speaking.

Procedure

1. Select **Talk**.
2. From the **PTT Channels** screen, select a channel.
A list is displayed with the default channel, the most recent channel you sent a broadcast on, and other channels you can broadcast on.
3. Press and hold **Talk** to start the broadcast.
Be sure to hold **Talk** throughout the entire broadcast.
A transmitting beep is played then the phone displays the channel information.
4. Begin speaking.
5. When you finish your broadcast, do one of the following:
 - Release **Talk**.
When you release Talk while sending the broadcast, the broadcast temporarily stops and enters a 10-second waiting period. During this period, the channel remains open to give others a chance to reply. At any time during the waiting period, you can resume your broadcast by pressing and holding Talk. If no one broadcasts during the waiting period, the channel closes and the broadcast ends.
 - Select **End PTT**.
After you select End PTT, you can immediately initiate another broadcast on another channel, even if the previous broadcast is in the waiting period.

Related Links

[Change the Default Channel](#) on page 98

Receiving PTT Broadcasts

To receive a broadcast sent on a particular channel, you need to be subscribed to that channel.

How you receive a PTT broadcast depends on the broadcast priority, whether you are in an active call, and whether your phone is set up to receive broadcasts during active calls.

When you enable Do Not Disturb on your phone, you receive only Emergency broadcasts. Non-emergency broadcasts do not display or play on your phone.

Related Links

[Update Channel Subscriptions](#) on page 98

Listen to a PTT Broadcast during an Active Call

How you handle a broadcast when you are in an active call depends on the broadcast priority and if your phone is set up to receive a broadcast when you are in an active call.

The following occurs when you receive a broadcast during an active call:

- When your phone is set up to receive Normal broadcasts during an active call, the broadcast immediately plays. You hear both the active call and the broadcast.
- When your phone is not set up to receive broadcasts during active calls, the broadcast is displayed as a Pending broadcast.
- When the broadcast is a Priority or Emergency broadcast, the broadcast plays immediately. You hear the active call and the broadcast.

Procedure

1. Do one of the following,
 - For broadcasts that play automatically during a call, hold the call to hear only the broadcast.
 - For Pending broadcasts, select **Accept** or hold the call.

Receiving PTT Broadcasts When Not in an Active Call

When you receive a broadcast and you are not in an active call, the broadcast immediately plays, regardless of the broadcast priority.

When you adjust the volume of a non-emergency broadcast, your phone retains the adjusted volume for all subsequent non-emergency broadcasts. However, only system administrators can adjust the volume level of an Emergency broadcast.

Reply to PTT Broadcasts

When a broadcast ends, the broadcast enters a 10-second waiting period. During this period, the channel remains open to receive or send additional broadcasts.

Procedure

1. During the 10-second waiting period, press and hold **Talk**
2. Begin talking.
The broadcast is sent to all people listening on the channel.
3. When you finish talking, release **Talk**.
The broadcast enters another waiting period until someone broadcasts again. If no activity occurs within the waiting period, the channel closes and no more broadcasts can take place.

End PTT Broadcasts

After you end a broadcast, the channel remains open so others can respond.

Procedure

1. Do one of the following:
 - Release **Talk**:
The broadcast enters a waiting period, and you cannot initiate another broadcast on another channel until the waiting period ends.
 - Select **End PTT**:
The broadcast ends, and you cannot resume the broadcast by pressing and holding Talk on the same channel. You can immediately initiate another broadcast on another channel.

Push-To-Talk Settings

This section provides information on the changing your default channel, updating channel subscriptions, and enabling broadcasts to play during active calls.

Note: The features described in this section require access to the Basic settings menu on the phone. If your phone requires a password to access the Basic settings menu, contact your system administrator for assistance customizing your phone.

Change the Default Channel

When you press and hold Talk, your broadcast automatically transmits on the default channel 1. You can change your default channel to any other channel. When you change the default channel, you are automatically subscribed to the channel you selected.

Procedure

1. Navigate to **Settings >Basic > Preferences > Paging/PTT Configuration > PTT Push to Talk**.
2. From the **PTT Channel Configuration** screen, select **Default Channel**, and select the number of the channel you want to use.

Related Links

[Send a PTT Broadcast](#) on page 95

Update Channel Subscriptions

You can subscribe to any channel that has been enabled by your administrator and appears in your channels list. When you subscribe to a channel, you can send and receive PTT broadcasts on that channel.

Procedure

1. Navigate to **Settings >Basic > Preferences > Paging/PTT Configuration > PTT Push to Talk**.
2. From the **PTT Channel Configuration** screen, select **Channel Subscriptions**.
3. From the **Channel Subscriptions** screen, select the channel you want to subscribe to, and select **Yes**.

Related Links

[Receiving PTT Broadcasts](#) on page 96

Enable PTT Broadcasts to Play During Active Calls

The *Accept While Busy* setting determines what happens when you are in a call and receive a PTT broadcast. The default setting is disabled by default, and when disabled, your phone does not play broadcasts while you are in a call, but holds them in a Pending state instead. When you enable the *Accept While Busy* setting, a PTT broadcast interrupts active calls and you hear the audio of the call and the broadcast.

Procedure

1. Navigate to **Settings >Basic > Preferences > Paging/PTT Configuration > PTT Push to Talk**.
2. From the **PTT Channel Configuration** screen, select **Accept While Busy**, and select **Enable**.

Phone Applications

Topics:

- [Using the Calendar](#)
- [Navigating the Browsers](#)

VVX phones can support optional applications configured by your system administrator. Ask your system administrator if your phone supports any of the applications discussed in this section.

Note: Some of the features described in this section require access to the Basic settings menu on the phone. If your phone requires a password to access the Basic settings menu, contact your system administrator for assistance customizing your phone.

Using the Calendar

When a VVX Business Media Phone is connected to Microsoft Exchange Server, you can view and join meetings scheduled in Microsoft Outlook from the phone.

Related Links

[Check the Status of the Calendar](#) on page 152

Open the Calendar

You can access the calendar on a VVX Business Media Phone to view and join scheduled meetings.

Procedure

1. Select **Calendar** from the Home screen or navigate to **Settings > Features > Calendar**.

The calendar displays your meetings for the day.

Note: If you do not see the Calendar icon on the Home screen or the Calendar does not display when selected, it is possible your login credentials are incorrect or the Calendar is not connected.

Related Links

[Check the Status of the Calendar](#) on page 152

Navigate to Other Views

From Day view, you can also access other calendar views: Month and Meeting view. Note that month view is not available on VVX 201 phones.

Procedure

1. Do one of the following:
 - Select **Month** or tap  to access Month view.

- Select a meeting to display Meeting view.

Display Meeting View

Meeting view displays the details for a chosen meeting. From Meeting view, you can view the meeting's start and end time, location, organizer, required attendees, and meeting description; view meeting numbers that you can call to join meetings; and join meetings.

Procedure

1. Do one of the following:
 - From **Day** view, select a meeting.
 - From **Month** view, select a date and select a meeting.

Meeting Reminders

When you have a scheduled meeting on the calendar, a meeting reminder displays and a tone plays 5 to 15 minutes before a meeting starts.

Note: If you have enabled meeting reminders but the reminders do not display before meetings, make sure that your login credentials are correct.

Respond to Meeting Reminders

From the reminder, you can join a meeting, view meeting details, snooze the reminder to temporarily remove the reminder from the screen, and dismiss the reminder to permanently remove the reminder from the screen and stop all future reminders for the meeting. The following figure shows a meeting reminder.

Meeting reminder on VVX 500 series phones

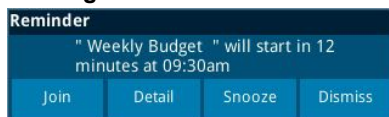

Procedure

1. Do one of the following:
 - Select **Join** to join the meeting.
 - Select **Detail** to view information for the meeting.
 - Select **Snooze** to temporarily remove the meeting reminder from your screen for one minute.
 - Select **Dismiss** to permanently remove the reminder for this meeting.

Choose a Meeting Reminder Type

You can choose a meeting reminder type that determines if an alert tone plays each time a meeting reminder displays.

The following options are available for meeting reminders:

- **Silent**—The meeting reminder is displays without an alert tone.

- Audible Once—An alert tone plays the first time a meeting reminder displays but does not play for any additional reminders.
- Audible Always (default)—An alert tone plays each time a meeting reminder displays.

Procedure

1. Navigate to **Settings > Basic > Preferences**.
2. Select **Calendar Settings > Reminder Settings**.
3. Select **Reminder Type** and choose a meeting reminder type.

Choose a Meeting Alert Tone

You can choose the alert tone that plays for meeting reminders.

Procedure

1. Navigate to **Settings > Basic > Preferences > Calendar Settings**.
2. Select **Calendar Settings > Alert Tone**.
3. Choose an alert tone and select **Play** to hear the tone.

Disable Meeting Reminders

Meeting reminders are enabled by default and display reminders for all meetings. You can choose to disable meeting reminders so they do not display for any meetings.

Procedure

1. Navigate to **Settings > Basic > Preferences**.
2. Select **Calendar Settings > Reminder Settings**.
3. Select **Reminder > Disable**.

Joining Calendar Meetings

You can join any scheduled meeting from the calendar or from a meeting reminder.

Join Meetings from the Calendar

You can join meetings on VVX Business Media Phone from the Calendar in Meeting view.

Procedure

1. From **Day** view, select the meeting.
2. In **Meeting** view, select **Join**.

Join a Meeting from a Meeting Reminder

You can join a meeting from the meeting reminder when it displays before a meeting, if enabled.

Procedure

1. On the meeting reminder, select **Join**.

The meeting details display.

2. Select **Join** to connect to the meeting.

Join Skype for Business Meetings from the Calendar

You can join Skype for Business meetings from the Calendar either from meeting reminders or Meeting view.

Procedure

1. From **Day** view, select the meeting.
2. In **Meeting** view, select **Join**, as shown next.

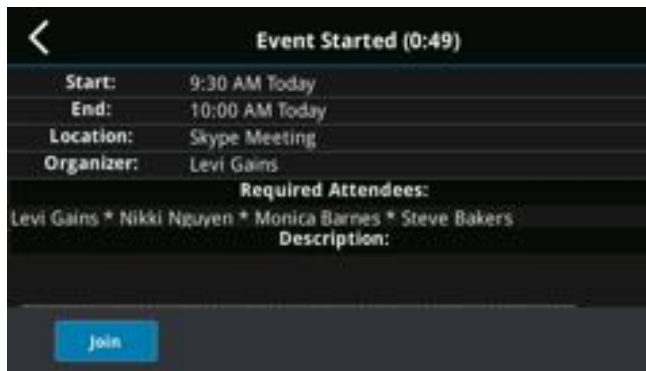

Navigating the Browsers

VVX phones support the following types of browsers:

- *Idle Browser* Displays non-interactive web content
- *Web Browser* Enables you to search and navigate web pages

The Idle Browser shows non-interactive web content on the Lines screen that displays when your phone doesn't have any calls in progress. Your system administrator determines what displays on the Idle Browser for your phone.

The Web Browser is an interactive browser that you can use to search the Internet and view web pages. From the Web Browser, you can select hyperlinks to view more web pages, enter information into text boxes, and scroll through web pages. There are scrolling indicators on the screen that indicate your position on the web page.

Ask your system administrator if the Idle and Web browsers are available on your phone.

View the Idle Browser

When your phone is idle, you can view an Idle Browser when you switch between the Home and Lines screens. To see the Idle Browser, you need to enable the screen saver.

Procedure

1. When your phone is not in a call, press .

Related Links

[Enable Screen Savers](#) on page 112

Open the Web Browser

When you open the Web Browser, a toolbar with navigation and editing soft keys display for three seconds along the bottom of the screen, as shown next. You can use the navigation and editing soft keys to navigate between web pages and enter information into text boxes in the Web Browser.

Navigation bar in the Web Browser



Procedure







1. From the **Home** screen, select **Applications**.

Browser Navigation Soft Keys

The navigation soft keys in the Web Browser enable you to view previous web pages, refresh the current page, return to the browser's Home page, or return to your phone's Home screen.

The following table lists the navigation soft keys that display in the Web Browser.

Navigating the Web Browser

| Icon | Action |
|---|---|
|  | Returns to the previous web page. |
|  | Refreshes the current web page. |
|  | Returns to the browser's home page. |
|  | Displays the toolbar permanently so it does not hide every three seconds. |
|  | Enables the toolbar to hide every three seconds. To display a hidden toolbar, you have to press the touchscreen until the toolbar displays. (VVX 500/501, and 600/601 phones) |
|  | Exits the Web Browser and returns to the phone's Home screen. |

VVX Business Media Phone Settings

Topics:

- [Password Required to Access Basic Settings](#)
- [Set the Language](#)
- [Change the Time and Date Format](#)
- [Backlight Intensity and Timeout](#)
- [Changing Your Background](#)
- [Customizing Line Keys](#)
- [Screen Savers](#)
- [Use Your Phone as a Digital Picture Frame](#)
- [Power-Saving Mode](#)
- [Changing Audio Settings](#)
- [Update Your Skype for Business Presence](#)
- [Adding a Profile Photo to Display on the Lock Screen](#)

This section explains how to make some basic customizations, which includes changing the time and date format, setting a language, and adjusting the screen brightness.

Password Required to Access Basic Settings

Many of the features on the phone can be enabled or customized from the Basic settings menu. However, if your system administrator has set up the phone to require a password to access the Basic settings menu, you cannot change settings without the permission of your system administrator. Contact your system administrator for assistance enabling or customizing features.

Set the Language

The phone supports several languages that you can choose to display. Check with your system administrator to find out exactly which languages are supported.

Procedure

1. Navigate to **Settings > Basic > Preferences**.
2. Select **Language** and select a language.
The language on the phone updates automatically.

Change the Time and Date Format

You can customize the time and date by choosing between a variety of time and date formats, including options to display the day, month, or year.

Procedure

1. Navigate to **Settings > Basic > Preferences**.
2. Select **Time & Date** and select one of the following:
 - Select **Clock Date** to change the date format.
 - Select **Clock Time** to change the time format.
 - Select **Clock Order** to change the order of the time and date display (not available on VVX 201 phones).
3. From the **Clock Date**, **Clock Time**, or **Clock Order** screen, select the format you want.

Related Links

[Set the Time and Date Format](#) on page 31

Disable the Time and Date Display

You can turn off the time and date display so that they do not display at all.

Procedure

1. Navigate to **Settings > Basic > Preferences**.
2. Select **Time & Date** and select **Disable**.

Backlight Intensity and Timeout

You can change settings for the following backlight components:

- **Backlight Intensity**—The brightness of the screen during phone activity and inactivity.
- **Backlight Timeout**—The number of seconds the phone is inactive before the backlight dims to its Backlight Idle intensity. The backlight timeout period begins after your last activity, such as an incoming call.

Backlight Intensity includes the following settings you can choose from:

- **Backlight On**—The brightness of the screen when there is activity.
- **Backlight Idle**—The brightness of the screen when there is no activity.
- **Maximum Intensity**—The brightness scale that applies to both Backlight On and Backlight Idle intensities.

This feature is not available on VVX 101 phones. Check with your system administrator to find out if this feature is available on your phone.

Related Links

[Changing the Backlight Intensity on VVX Expansion Modules](#) on page 136

[Features for Vision-Impaired and Blind Users](#) on page 147

Set the Backlight Intensity

You can change the Backlight On intensity and the Backlight Idle intensity separately, and you can choose a high, medium, or low intensity, or turn off the backlight entirely. When you change the Maximum Intensity, you modify the entire backlight intensity scale. For example, if you decrease the Maximum Intensity, the low, medium, and high levels for both Backlight On and Backlight Idle intensities decrease.

Procedure

1. Navigate to **Settings > Basic**.
2. Select **Backlight Intensity > Backlight On Intensity**.
3. Select the intensity you want, and select **Back**.
4. From the **Backlight Intensity** screen, select **Backlight Idle Intensity**.
5. Select the intensity you want, and select **Back**.
6. From the **Backlight Intensity** screen, select **Maximum Intensity**.
7. Select **Up** or **Down**, or drag your finger along the slider, to increase or decrease the maximum intensity.

Set the Backlight Timeout

The backlight automatically turns on with any phone activity. By setting the Backlight Timeout, you can determine how long the phone should be idle before the backlight dims to its Backlight Idle intensity. By default, the backlight dims after the phone is idle for 40 seconds.

Procedure

1. Navigate to **Settings > Basic**.
2. Select **Backlight Timeout**.
3. Select the number of seconds the phone is idle before the backlight dims.

Changing Your Background

By default, your screen displays a blue background named Default. You can change the background picture that is displayed on your phone to any image set up by your system administrator. If no background images are set up, only the Default is available.

You can also add personal photos on your phone using the Web Configuration Utility or a USB flash drive.

This feature is not available on V VX 201 phones. Check with your system administrator to find out if this feature is available on your phone.

Change the Background Picture

If your system administrator has pre-loaded your phone with background pictures or you have added personal photos onto the phone, you can choose to display a background other than the default.

Procedure

1. Navigate to **Settings > Basic > Preferences > Background**.

Depending how your system is set up, you might have to navigate to **Settings > Basic > Preferences > Background > Select Background**. The **Select Background** screen is displayed instead.

2. Select a background image, if available.

Related Links

[Adding Personal Photos as Your Background](#) on page 107

Adding Personal Photos as Your Background

You can upload a personal photo to use as your background using the Web Configuration Utility or using a USB flash drive. When you set one of your pictures as the background picture, the picture is displayed as *Local File* in the Backgrounds list.

Keep in mind the following when you use a personal photo as the background image:

- Progressive or multiscan JPEG images are not supported.
- The phone screen sizes vary by phone:
 - VVX 300 series and 400 series phone screens are 220 x 108 pixels
 - VVX 500 series phone screens are 320 x 240 pixels
 - VVX 600 series phone screens are 480 x 272 pixels.
- Smaller images are centered and surrounded with black space.
- Larger images are scaled proportionally to fit the screen.
- Horizontal or vertical black bars are added to preserve the original aspect ratio.

Related Links

[Change the Background Picture](#) on page 106

Add a Background Using the Web Configuration Utility

You can add one or multiple images for your phone background using the Web Configuration Utility.

Note: On Polycom phones with UC Software 5.1.1 or later and registered with Skype for Business Server, access to the Web Configuration Utility is disabled by default as a security precaution. Contact your system administrator for help enabling the Web Configuration Utility.

Procedure

1. Find you phone's IP address by navigating to **Settings > Status > Platform > Phone**.
2. Enter your phone's IP address into the web browser on your computer.
3. Select **User**, and enter your assigned password or the default (**123**) password.
4. From the menu bar, select **Preferences > Background**.
5. Click **+ Add a new background image**.
6. Click **Select a file from PC/Desktop**, and click **Choose File for Phone Image**.
7. Choose your picture file, and click **Open**.

8. Click **Save**.

The file is added to the list of available backgrounds.

9. On your phone, navigate to **Settings > Basic > Preferences > Background**.

10. Select your background image.

The image is displayed as your background.

Use a USB Flash Drive to Add a Background

You can add personal photos as your background using a USB flash drive on V VX 401/411, 500/501, and 600/601 phones.

Before you can set a picture on your USB flash drive as the background picture, make sure the picture is on a USB flash drive and is not in a folder on the drive.

Note: If your phone does not detect the USB flash drive when you attach it to your phone, the USB port on your phone may be disabled. Contact your system administrator.

Procedure

1. Attach a USB flash drive to the USB port on your phone.
2. Navigate to **Settings > Features > Removable Storage Media > Picture Frame**.
Your pictures display, one-by-one.
3. Tap the arrow keys to find your picture, and then tap .

The picture you selected is displayed on the Home and Lines screens.

Note: If your pictures on the flash drive are in a subfolder and not in the root directory, the phone displays a message stating that there are no available photos. Make sure the picture you want to display on your phone is not in a subfolder on the flash drive.

Reset Your Background

You can reset your background to display the default image.

Procedure

1. Navigate to **Settings > Basic > Preferences > Background**.
2. From the **Background** screen, select **Default**.

Customizing Line Keys

On V VX 300, 400, 500 and 600 series business media phones, you can customize the line keys that display on the Lines screen in the following ways:

- Set a transparent background to show for line keys
- Choose the number of columns that display
- Assign a contact to a line on the phone or an expansion module for up to 100 contacts

- Display only your line registration on the Lines screen
- Insert an empty line between line keys
- Clear a contact from a line key or delete a line key
- Reset all custom line keys

This feature is not available on V VX 201 phones. Check with your system administrator to find out if this feature is supported on your phone.

Customize the Columns on the Lines Screen

When you add contacts or favorites to line keys on the Lines screen, the contacts display in columns. On V VX 500/501 and 600/601 phones, you can control how many columns of line keys display on the Lines screen. By default, the phone displays the maximum number of columns and line keys. The following are the maximum line keys and columns that display on each phone:

- V VX 500/501: 3 columns with 12 line keys
- V VX 600/601: 4 columns with 16 line keys

Procedure

1. Navigate to **Settings > Basic > Preferences > Idle Screen Settings**.
2. Select **Columns**, enter the number of columns you want to display.
For V VX 500/501, enter a number between 1-3; For V VX 600/601, enter a number between 1-4.
3. Press **Save**.

Enable Transparent Line Keys

By default, your phone displays line keys with a background. If you have a background picture set on your V VX phone, the background is partially or fully covered depending on the number of line keys you have.

On V VX 500/501 and 600/601 phones, you can change line keys to have a transparent background that enables you to fully see the background you set for your phone.

Procedure

1. Navigate to **Settings > Basic > Preferences > Idle Screen Settings**.
2. On the **Idle Screen Settings** screen, select **Transparent Lines**, and select **Enabled**.

The line keys are displayed without a background, as shown next.



Show Only Your Line Registration

By default, your line registration and any Skype for Business contacts or favorites you add on the phone display on the Lines screen. You can choose to set your phone to only display your line registration on the Lines screen.

If you have a V VX Expansion Module connected to your phone, your contacts and favorites are moved onto the expansion module.

Procedure

1. Navigate to **Settings > Basic > Preferences > Idle Screen Settings**.
2. Select **Show only registration** and select **Enabled**.

Enable Line Key Customization

When you are signed into Skype for Business on your V VX phone, you can enable the Line Key Customization feature and choose which contacts are assigned to which line keys on the phone or V VX Expansion Module.

Procedure

1. Navigate to **Settings > Basic > Line Key Customization**.
2. Select **Customize Line Keys: Disabled** then select **Enabled**.

Related Links

[Assign Skype for Business Contacts to Line Keys](#) on page 85

[Assign Skype for Business Contacts to V VX Expansion Modules](#) on page 133

Insert an Empty Line Key

By default, the phone inserts new or empty lines below previously added lines. If you want to place space between line keys, you can insert an empty line key above or below other line keys on the phone or expansion module.

When you insert an empty line, all following line keys are moved down a line, and the last contact is removed from the Lines screen.

Procedure

1. Navigate to **Settings > Basic > Line Key Customization**.
2. Choose one of the following:
 - **Phone Line Keys**.
 - **Expansion Module Line Keys**.
3. Select a line then select **Insert**.
By default, the new line is inserted above the selected line.
4. Select **Below** to move the line below the selected line.

Clear a Line Key

You can clear a contact from a line so that the line is blank. Clearing a contact does not change the position of other contacts.

Procedure

1. Navigate to **Settings > Basic > Line Key Customization**.
2. Choose one of the following:
 - **Phone Line Keys**
 - **Expansion Module Line Keys**.
3. Select a line and press **Clear**.

Delete a Line Key

Instead of clearing a line key, you can delete a contact and the assigned line key. When you delete a line key, all line keys below move up one line.

When you delete a contact from the Skype for Business client on your computer, the contact is removed from the line key, but the line key is not deleted from the phone.

Procedure

1. Navigate to **Settings > Basic > Line Key Customization**.
2. Choose one of the following:
 - **Phone Line Keys**.
 - **Expansion Module Line Keys**.
3. Select a line and press **Delete**.

Reset Customized Line Keys

If for some reason you need to remove all of the customized line keys you set, you can reset the line keys on your phone and expansion module.

Procedure

1. Navigate to **Settings > Basic > Line Key Customization**.
2. Choose one of the following:
 - **Phone Line Keys**.
 - **Expansion Module Line Keys**.
3. Select **Reset Customization**.

Screen Savers

Another way to personalize your phone is to enable a screen saver that can either show default pictures stored on your phone, the idle browser, or pictures stored on a USB flash drive. Ask your system administrator if this feature is available on your phone.

Enable Screen Savers

The screen saver automatically starts each time your phone is idle for a certain amount of time. When you enable the screen saver, you can choose to have your phone either display default photos stored on the phone, or the idle browser.

You can stop the screen saver at any time by pressing any key or touching the screen. When your phone is idle again for a specified period of time, the screen saver starts again.

Procedure

1. Navigate to **Settings >Basic > Preferences > Screen Saver**.
2. From the **Screen Saver** screen, select **Screen Saver** and select **Enabled**.
3. Select **Wait Time** and enter the number of minutes the phone can wait after no activity before displaying the screen saver.
You can enter any time between one and 9999 minutes. The default time is 15 minutes.
4. Select **Type** and select either **Default** or **Idle Browser**.
5. Press **Save**.

Related Links

[View the Idle Browser](#) on page 102

Use Personal Photos as Screen Savers

On V VX 401/411, 500/501, and 600/601 phones, you can enable your phone to display your personal photos as a screen saver. To set up a screen saver of your pictures, you need to set up certain screen saver settings, place your pictures on a USB flash drive, and attach the USB flash drive to the phone.

The pictures you use must have the following file type and size properties:

- File type: BMP, JPEG, or PNG
- Maximum size: 9999 x 9999 pixels

The phone can only display the photos as your screen saver when the USB flash drive is attached to the phone.

You can set up your phone to use a single picture to display or have all pictures display in slide-show style. This is an alternative to setting up a screen saver, and it automatically starts each time your phone is idle a certain amount of time.

Procedure

1. Place one or more pictures on a USB flash drive, either in the root directory or in a folder.
2. Attach the USB flash drive to your phone.
The USB icon  is displayed on the status bar.
3. Navigate to **Settings > Basic > Preferences > Picture Frame**.
4. From the **Picture Frame** screen, select **Folder**, and enter the name of the folder you placed your images in on the USB flash drive.
If you did not place the pictures in a folder, but placed them in the root directory instead, do not enter a folder name.
5. Select **Time Per Image**, and enter the number of seconds you want each picture to display.

You can enter a minimum of 3 seconds and a maximum of 300 seconds. The default is 5 seconds.

6. Select **Save.**

If the message “No pictures found” displays after you select **Save**, there are no pictures in the folder you specified or in the root directory. Go back and make sure the information you entered is correct.

7. Navigate to **Settings > Basic > Preferences > Screen Saver.**

8. From the **Screen Saver screen, select **Screen Saver**, and select **Enabled**.**

9. Select **Wait Time, and enter the number of minutes the phone should wait, after no activity, before displaying the screen saver.**

You can enter any time between one minute and of 9999 minutes. The default is 15 minutes.

10. Select **Save.**

Your phone displays the screen saver after the number of minutes you specified in the Wait Time field.

Note: If your phone does not detect the USB flash drive when you attach it to your phone, the USB port on your phone may be disabled. Contact your system administrator.

Related Links

[Overview of Phone Hardware and Keys](#) on page 11

Disable the Screen Saver

You can stop a screen saver at any time by touching the screen. After your phone is idle for the specified period of time, the screen saver starts again.

You can disable a screen saver—prevent it from starting, even if your phone has been idle for the specified period of time—by doing the following:

- Removing the USB flash drive. The screen saver does not display until you attach the USB flash drive again, and your phone is idle for the period of time you specified.
- Disabling the Screen Saver setting. When you disable the setting, the screen saver does not display, even though the USB flash drive is still attached.

Procedure

1. Navigate to **Settings >Basic > Preferences > Screen Saver.**

2. From the **Screen Saver screen, select **Screen Saver**, and select **Disabled**.**

3. Select **Save.**

Use Your Phone as a Digital Picture Frame

On V VX 401/411, 500/501, and 600/601 phones, you can use the Picture Frame feature to view pictures stored on your USB flash drive at any time without setting up a screen saver. You can display your pictures as thumbnails, one-by-one as a slide show, or display just one picture.

Before you can display your pictures, confirm that your pictures are on the USB flash drive, and that the USB flash drive is attached to your phone.

Note: If your phone does not detect the USB flash drive when you attach it to your phone, the USB port on your phone may be disabled. Contact your system administrator.

Procedure

1. Select **Settings > Features > Removable Storage Media > Picture Frame**.

Your pictures display one-by-one, like a slide show, and navigation icons display beneath your pictures, as shown next.









Related Links

[Overview of Phone Hardware and Keys](#) on page 11

Picture Frame Icons

Use the icons in the following table to perform actions in the Picture Frame.

Picture Frame Icons

| Icons | Action |
|---|--|
|  | View thumbnails of your pictures. |
|  | View the previous picture. |
|  | View the next picture. |
|  | Pause and display the current picture only. |
|  | Starts the display of pictures one-by-one again. |
|  | Stop displaying the pictures. The pictures do not display again until you access the Picture Frame feature (unless you have a screen saver enabled). |
|  | Set the picture that currently displays as the background picture for your phone. |

Power-Saving Mode

By default, the phone is set to enter power-saving mode and turn off the screen after being idle for a certain period of time to conserve energy. You can determine the period of time that the phone is idle before the screen turns off, and you can set different idle timeouts for office hours and off hours, such as evenings and weekends.

When power-saving mode is activated, the phone exits power-saving mode if an event occurs—for example, if there is an incoming call or message. If a screen saver is enabled, power-saving mode still occurs.

You can update the following power-saving settings:

- Office Hours—When you start work and how long you're in the office each day.
- Timeouts—The period of time the phone should be idle before the screen turns off.

Change Your Office Hours

When you update your office hours, you specify when you start and how long you work each day. After your work hours, the phone is idle and goes into power-saving mode.

Procedure

1. Navigate to **Settings > Basic**.
2. Select **Power Saving > Office Hours** and select **Start Hour**.
3. Select a day of the week, and using the 24-hour clock, enter a start time from 0 to 23.
4. Select **Save**.
5. From the **Office Hours** screen, select **Duration**.
6. Select a day of the week and enter a duration of 0 to 12 hours per day..
7. Select **Save**.

Change Timeouts

You can update the period of time the phone is idle before the screen turns off. You can specify different timeouts for office hours (Office Hours Idle Timeout) and non-office hours (Off Hours Idle Timeout). By default, the Office Hours Idle Timeout is much longer than the Off Hours Idle Timeout.

You can also specify a separate timeout period that applies after you press a key or tap the screen. This is called the User Input Idle Timeout. You can choose to set a higher User Input Idle Timeout than the Office Hours and Off Hours Idle Timeouts so that when you're actively using the phone, power-saving mode doesn't initiate as often.

Tip: If you press a key or tap the screen, the idle timeout period that applies (User Input Idle Timeout or Office Hours/Off Hours Idle Timeout) is the timeout with the highest value.

Procedure

1. Navigate to **Settings > Basic**.
2. Select **Power Saving > Timeouts**.

3. Select **Office Hours Idle Timeout** and enter the number of minutes (1 to 600 minutes) the phone should wait, during office hours, before starting power-saving mode.
4. Select **Off Hours Idle Timeout**, and enter the number of minutes (1 to 10 minutes) the phone should wait, during off-hours, before starting power-saving mode.
5. Select **User Input Idle Timeout**, and enter the number of minutes (1 to 10 minutes) the phone should wait after a key press or screen select before starting power-saving mode.
6. Select **Save**.

Changing Audio Settings

You control certain audio settings on your phone, including the ringtone for incoming calls from all contacts or a specific contact, where call notifications play, and the volume or the ringtone or call audio.

Related Links

[Features for Hearing-Impaired Users](#) on page 145

Change Incoming Call Notifications

You can choose whether you hear sound effects—all phone sounds except call audio—from the handset, headset, speaker, or the active audio device you set. For example, you can configure your phone to ring on your headset instead of the speaker. By default, you hear all sound effects from the speaker.

Procedure

1. Navigate to **Settings > Basic > Preferences > Audible Ringer**.
2. From the **Audible Ringer** screen, select a location to hear sound effects.

Set a Ringtone for Incoming Calls

A simple way to personalize your phone is to change your phone's ringtone. You can pick unique ringtones for the different lines on your phone. The default ringtone is Low Trill.

Procedure

1. Navigate to **Settings > Basic > Preferences**.
2. Select **Ring Type**.
3. If there are multiple lines on your phone, select a line.
4. From the **Ring Type** screen, select a ringtone.
5. Select **Play** to hear the ringtone.

Set a Ringtone for Individual Contacts

You can select unique ringtones for various contacts in your directory, which helps you quickly identify callers as your phone rings.

Procedure

1. From your **Contact Directory**, select a contact.

2. From the **Contact Information** screen, select **Edit** or tap .
3. From the **Edit Contact** screen, select **Ring Type** and select a ringtone.
4. Select **Play** to hear the ringtone.
5. From the **Edit Contact** screen, select **Save**.

Change the Volume

You can increase the volume of your ringtone and the audio during a call.

Procedure

1. Press one of the Volume keys  to increase or decrease the audio.

Update Your Skype for Business Presence

You can update your Skype for Business presence status and presence information on the phone. When you change your presence on any device, the information is automatically updated in the Skype for Business client.

Procedure

1. Press the **MyStatus** soft key or navigate to **Settings > Features > Presence > My Status**.
2. Choose your desired presence status.
You can change your status to Available from any other status by pressing **Reset Status**.

Related Links

[Skype for Business Contacts' Presence Information](#) on page 86

Adding a Profile Photo to Display on the Lock Screen

If you do not have a profile photo set for your Skype for Business or Microsoft Exchange accounts, an avatar displays on the Lock screen when you lock your phone. You can add a profile photo in the Skype for Business client, and the photo will display on the phone.

Profile photos do not display on V VX 201 or V VX 300 series business media phones.

For help with setting a profile photo, refer to the [Set My Picture options in Skype for Business](https://support.office.com/en-us/skype-for-business) topic on <https://support.office.com/en-us/skype-for-business>.

Related Links

[Lock Your Phone](#) on page 33

Phone Accessories and Computer Applications

Topics:

- [Using a Headset with Your Phone](#)
- [Controlling Your Phone with Polycom Desktop Connector](#)
- [Connecting a Netgear Wi-Fi Adapter to Your Phone](#)
- [Connecting Polycom VVX Expansion Modules to Your Phone](#)
- [Connecting to Skype for Business on Your Phone using Better Together over Ethernet](#)

This section describes accessories and applications that you can use to extend your phone's capabilities. Your phone may not support all of the accessories or applications described in this section. Check with your system administrator to find out which of these applications or accessories are available on your phone.

Note: Some of the features described in this section require access to the Basic settings menu on the phone. If your phone requires a password to access the Basic settings menu, contact your system administrator for assistance customizing your phone.

Using a Headset with Your Phone

You can connect a headset to your VVX phone and use the headset to place and answer calls, handle all calls using a headset, and use electronic hookswitch (EHS).

You can connect an analog headset to all VVX phones or a USB headset to VVX 401/411, 500/501, and 600/601 phones. You can also pair and connect a Bluetooth headset with your VVX 600/601 phone.

See *Feature Profile 37477: Using Headsets with Polycom Phones* on [Polycom Support](#) for a list of compatible headsets.

Note: For information on your headset's features, as well as how to sync your headset with your phone, see your headset's documentation.

Connecting a Headset

Your phone does the following when connected to analog and USB headsets:

- When an analog headset is connected and in use, the headset key glows green. Note that the headset key does not glow on VVX 201 phones.
- When a USB headset is connected and in use, the headset key glows blue.
- When both an analog and USB headset are connected, the USB headset is used automatically for all calls.
- When two USB headsets are connected, the headset you connected first is used automatically for all calls.

After you connect a headset to your phone, you can set up your phone to use the headset automatically when answering and placing calls.

For setup information on how to connect a headset to your phone, see the *Quick Start Guide* for your phone on the [Business Media Phones Support](#) page.

Note: If your phone does not detect the USB headset when you attach it to your phone, the USB port on your phone may be disabled. Contact your system administrator.

Use Your Headset for All Calls

You can set up your phone so that all incoming and outgoing calls automatically use your headset. To use this feature, you must enable and activate Headset Memory Mode.

Procedure

1. Navigate to **Settings >Basic > Preferences > Headset > Headset Memory**.
2. From the **Headset Memory Mode** screen, select **Enabled**.
3. Press the headset key twice.

The headset key flashes to indicate that Headset Memory Mode is now activated. All calls placed or answered on your phone use your headset automatically.

Note: If you or your contacts experience audio or echo issues during calls, such as feedback of your voice or of their own voice, you need to enable echo cancellation on your phone.

Related Links

[Switch among the Handset, Headset, and Speakerphone](#) on page 42

[Features for Hearing-Impaired Users](#) on page 145

[Features for Mobility-Impaired Users](#) on page 146

[Troubleshoot Audio and Echo Issues](#) on page 154

Reactivate Headset Memory Mode

Switching to the speakerphone or the handset deactivates Headset Memory Mode.

Procedure

1. Press the headset key twice.

Using Electronic Hookswitch

When you use a headset that supports electronic hookswitch (EHS), you can place, answer, and end calls by using the controls on your headset. To use EHS, you need a headset that includes a serial control interface in addition to the standard analog headset jack (RJ-9) interface. The serial control interface requires an EHS adapter that you can purchase from your headset manufacturer.

Headsets that support EHS include a base unit that connects to your phone. The headset connects to the base unit wirelessly, which enables you to use your headset even if you're some distance away from your phone. Typically, you can work wirelessly up to 300 feet (91 meters) from your phone and still use the EHS controls. Check with your headset's user guide for the precise range restrictions.

See Feature Profile 37477: Using Headsets with Polycom Phones on [Polycom Support](#) for a list of compatible headsets.

Setting the Headset Base Unit Options

Before you connect your headset to your phone and use EHS, you need to set the following options for your specific headset model:

- For Jabra headsets, change the headset mode to **DHSG** on the headset base unit. For details, refer to your headset documentation or contact Jabra support.
- For Plantronics headsets, change the coarse receive level to **3** and the transmit level to **B** on the headset base unit. For details, refer to the guide that comes with your headset.
- For Sennheiser headsets, set the first DIP switch labeled **1** (DHSG) to the down position on the back of the headset base unit. For additional details, see your headset's documentation or contact Sennheiser support.

Enable Electronic Hookswitch

After you set the base unit options for your headset and connect your headset to your phone, you can enable EHS.

Procedure

1. Connect your headset and EHS adapter to your phone.

See the Quick Start Guide for your phone on [Polycom Voice Support](#) for information on connecting a headset to your phone.

2. Navigate to **Settings > Basic > Preferences > Headset > Hookswitch Mode**.

3. Select one of the below modes for your specific headset:

- Choose **Jabra** if an EHS-compatible Jabra headset is attached with an EHS cable or adapter.
- Choose **Plantronics** if an EHS-compatible Plantronics headset is attached with an EHS cable or adapter.
- Choose **Sennheiser** if an EHS-compatible Sennheiser headset is attached with an EHS cable or adapter. If your phone does not have a menu selection for Sennheiser, select **Jabra** instead.
- Choose **Regular Mode** (default) if another headset is attached.

Related Links

[Features for Hearing-Impaired Users](#) on page 145

Change the Headset Mode

Headsets that come with a docking station have two modes: soft phone and desk phone mode. In order for you to control your phone using your headset, your headset must be in soft phone mode. If you cannot operate the phone from your headset, it is possible your headset is in desk phone mode.

Procedure

1. Press and hold the headset hookswitch until you hear a sound or message on the headset.

Controlling Calls with Electronic Hookswitch

After you have followed the procedures for connecting your headset and enabled EHS, you can use the controls on your headset to answer, mute, and end calls. If supported on your headset, you can also place calls on hold. See your headset's user documentation for information on controlling calls from your headset.

When you are in an active call and you receive an incoming call, you cannot use the hookswitch control on your headset to place the active call on hold and answer the incoming call. Pressing the hookswitch control on the headset ends the active call and answers the incoming call. To place the existing call on hold and answer the incoming call, answer the call on your phone.

Related Links

[Features for Mobility-Impaired Users](#) on page 146

Disconnect Your Headset

If you want to disconnect or change your headset, you need to properly detach your headset from your phone.

Procedure

1. Navigate to **Settings >Basic > Preferences > Headset > Hookswitch Mode**.
2. Select **Regular Mode**.
3. Remove the EHS adapter from the serial port on the back of the phone.

Using Bluetooth Headsets with VVX 600 Phones

VVX 600/601 phones support Bluetooth headsets as well as analog and USB headsets. If your system administrator has enabled Bluetooth capability for your phone, you can use a Bluetooth headset to handle calls. When a Bluetooth headset is connected and in use, the headset key  glows blue. If you have multiple types of headsets connected to your phone, the Bluetooth headset is used automatically for all calls.

This section provides you with information on how to enable Bluetooth on your VVX 600/601, how to pair and connect your Bluetooth headset, how to use your Bluetooth headset with your phone, and how to disconnect and remove your headset.

Enable Bluetooth and Connect a Headset



In order to use a Bluetooth headset with your phone, you need to enable Bluetooth, pair your headset, and connect your Bluetooth device to your phone. You can pair up to four Bluetooth headsets with your phone; however, you can connect only one headset at a time.

The following instructions are intended as a guide, and do not apply to all Bluetooth devices. You can usually find instructions for your headset on the device manufacturer's web site.

Procedure

1. Navigate to **Settings >Basic > Bluetooth Settings > Bluetooth Radio**.
The Bluetooth Radio screen is displayed.
2. Tap **On**.

The Bluetooth icon  is displayed in the status bar. After the icon displays, you can pair and connect your Bluetooth headset.



3. Turn your Bluetooth headset on and place the headset in **Discovery** mode.
Refer to your headset documentation for information on how to place your headset in discovery mode.
4. Navigate to **Settings > Basic > Bluetooth Settings > Manage BT Headsets**.
5. Tap **Scan** to find your headset.
All nearby devices in discovery mode are added to the list, and the Bluetooth icon  is displayed next to each unpaired headset.
6. Select your headset and tap **Add** to begin the pairing process.
After your headset is added, the Bluetooth Available icon  is displayed.
7. Select your headset and select **Connect**.
The Bluetooth Headset icon  is displayed next to your headset after the headset is paired and connected. The Bluetooth Headset icon is also displayed in the status bar. If you select the icon, the Bluetooth Settings screen is displayed.

Related Links

[Bluetooth Headset](#) on page 154

Managing Calls with Your Bluetooth Headset

When your Bluetooth headset is turned on, paired, and connected with your phone, you can perform the following tasks:

- Use the headset to handle calls, including muting and adjusting the call volume.
- Initiate and end calls on your headset by pressing the Headset key , or using a control on the headset.
- Switch to handset or speakerphone mode during a headset call by picking up the handset or pressing the Speakerphone key .

When you turn the headset off, the headset is no longer connected but remains paired to your phone. When you turn the headset back on, the headset is reconnected.

Disconnect and Remove Your Bluetooth Headset

You can disconnect your headset from your phone, but still keep it paired. When you disconnect a headset, it remains paired so you can easily connect it to your phone again.

You can also remove your headset so that it is no longer paired or connected. When you remove your headset, it won't display in the Manage BT Headsets screen. To connect it back to your phone, you'll need to scan for the device, add it, and connect it again.

Procedure

1. Navigate to **Settings > Basic > Bluetooth Settings > Manage BT Headsets**.
2. From the **Manage BT Headsets** screen, select your headset, and select **Disconnect**.
Your headset remains paired to your phone but is no longer connected.
3. Select your headset, and select **Remove**.

Your headset is removed from the list and is no longer paired or connected with your phone.

Tip: You can quickly disconnect your headset by turning your headset off. When you turn it off, the message “Headset removed” is displayed. When you turn your headset back on, the headset is connected again.

Controlling Your Phone with Polycom Desktop Connector

The Polycom Desktop Connector (PDC) enables you to use your computer mouse and keyboard to navigate and enter information on your phone. The PDC is compatible with any language your phone and computer supports. Contact your system administrator to find out if your phone supports the PDC.

This feature is not available on VVX 201 phones. Check with your system administrator to find out if this feature is available on your phone.

Related Links

[Features for Mobility-Impaired Users](#) on page 146

[Polycom Desktop Connector](#) on page 153

Setting Up and Enabling the Polycom Desktop Connector

Before you can enable and use the PDC, you need to download the PDC application from the [Polycom Voice Applications](#) website, install the application on your computer, and activate PDC on your phone.

To enable the PDC, you need to enter your computer access credentials to the phone. You can provide this information to your phone using one of two methods: Direct or Indirect. The method you use depends on how your phone and computer are set up.

After you install the software, you need to make changes to your phone to establish a connection to your computer and provide an exception to your firewall or anti-virus software to unblock the PDC program.

Use the Direct Method

If your phone and computer are connected using an Ethernet cable, use the direct method to enable the PDC. Using this method, your phone automatically detects your computer's access credentials.

Procedure

1. Click **Start > Programs > Polycom > Polycom Desktop Connector**.

The PDC icon is displayed as an active program on your taskbar, as shown next.

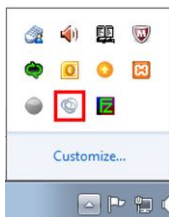

2. On your phone, navigate to **Settings > Basic >PDC Configuration**.

The PDC Configuration screen is displayed on your phone screen.

3. On the **PDC Configuration** screen, set the **Status** field to **Enabled** and select **Save**.
Your settings are saved and the Basic screen is displayed.
4. On the **PDC Configuration** screen, select **Reconnect**.
A dialog box is displayed on your phone screen asking if you wish to share your remote keyboard and mouse.
5. Select **Yes**
A dialog box is displayed asking you to specify your phone's position.
6. Specify whether your phone is to the left or right of your computer monitor.
A dialog box is displayed on your computer asking to allow remote control of your phone.
7. Click **OK** to complete the setup process.
The PDC icon turns red, shown next, indicating that you have successfully enabled the PDC program.

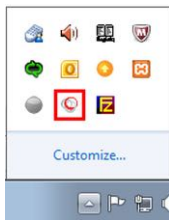

Using the Indirect Method

If your phone and computer are connected through a switch, use the indirect method to enable the PDC. This method requires you to find your computer's IP address and manually enter your computer access credentials.

Find Your Computer's IP Address

You can find your computer's IP address using the Command Prompt on your computer.

Procedure

1. Click **Start > All Programs > Accessories > Command Prompt**.
2. In the **Command Prompt**, type `ipconfig` and press **Enter**.
3. Note your server address on the **IPv4 Address** line, as shown next.

 A screenshot of a Windows Command Prompt window titled 'Administrator: C:\Windows\system32\cmd.exe'. The window displays the output of the 'ipconfig' command. The output shows details for 'Ethernet adapter Local Area Connection:' and 'Tunnel adapter {atap...}'. The 'Autoconfiguration IPv4 Address' line is highlighted with a red box, showing the value '169.254.8.31'. Other lines include 'Connection-specific DNS Suffix', 'Link-local IPv6 Address', 'Subnet Mask', and 'Default Gateway'.

```
Administrator: C:\Windows\system32\cmd.exe
Windows IP Configuration

Ethernet adapter Local Area Connection:

    Connection-specific DNS Suffix . . : 
    Link-local IPv6 Address . . . . . : fe80::3c3c:222f:aef5:81fx11
    Autoconfiguration IPv4 Address. . . : 169.254.8.31
    Subnet Mask . . . . . : 255.255.0.0
    Default Gateway . . . . . : 

Tunnel adapter {atap.<D7C94712-1984-441A-99EA-11AC6313E71B>}:

    Media State . . . . . : Media disconnected
    Connection-specific DNS Suffix . . :
```

Connect Using the Indirect Method

After you find your phone's IP address, you can start the PDC program and connect your phone to your computer using the indirect method.

Procedure

1. Click **Start > Programs > Polycom > Polycom Desktop Connector**.

The PDC icon is displayed as an active program on your taskbar as shown next.

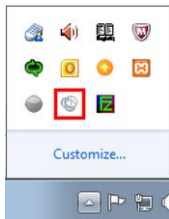

2. On your phone, navigate to **Settings > Basic >PDC Configuration**.
3. From the **PDC Configuration** screen, set the **Status** field to **Enabled**.
4. In the **Phone Orientation** field, specify whether your phone is to the left or right of your computer monitor.
5. In the **Desktop User** field, enter your Windows login name.

6. In the **Server Address** field, enter your computer's IP address or FQDN.

The IP address enables your phone to locate and identify your computer on the network.

7. Select **Save**.

Your settings are saved and the Basic screen is displayed, and a message is displayed asking you to allow sharing with your computer.

8. Select **Yes**.

A dialog box is displayed on your computer asking if you wish to allow remote control of your phone.

9. Click **OK** to complete the setup process.

The PDC icon turns red, shown next, indicating that you have successfully enabled the PDC program.

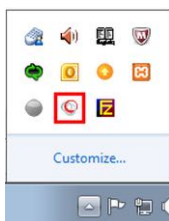

Disable the Polycom Desktop Connector

If you disable the PDC, you can no longer use your mouse and keyboard to control and enter information on your phone.

Procedure

1. Do one of the following:
 - On your computer, right-click the PDC icon on your taskbar and click **Exit**.
 - On your phone, navigate to the PDC Configuration menu and set the **Status** to **Disabled**.

In the system tray, the PDC icon turns grey.

Using the Polycom Desktop Connector

After you've configured and enabled the PDC, you can use your computer mouse and keyboard to click menus and enter text in the editable fields—the fields with a flashing cursor—on your phone.

Access Your Phone Screens

You can use your mouse to navigate your phone and access your phone's screens.

Procedure

1. Move your mouse pointer off the edge of your computer monitor in the direction of your phone—left or right—that you indicated in the setup process.

The pointer leaves your computer monitor and displays on the phone's screen.

Note: If your computer taskbar is on the same side as your phone, the taskbar will block your cursor from accessing your phone. Move your computer taskbar elsewhere to allow your cursor to access the phone.

Using Keyboard Shortcuts to Perform Tasks on Your Phone

The PDC extends your keyboard and mouse functionality onto your phone and enables you to do the following:

- You can right-click a field on your computer and select the cut or copy information and paste the information onto your phone. You can also cut, copy, and paste text from your computer onto your phone using keyboard shortcuts:
 - Cut (Ctrl+X)
 - Copy (Ctrl+C),
 - Paste (Ctrl+V).

You cannot cut, copy, and paste text from your phone to your computer.

- Copy and paste information between fields on your phone screen by right-clicking the field and choosing a clipboard command.
- Delete information on your phone by highlighting the information using your mouse and pressing the Delete or Backspace key on your keyboard.
- Use the Home and End keys on your keyboard to position your cursor at the beginning or the end of fields on your phone.
- Enter numeric information such as phone numbers using the number keys on your keyboard.





- Use the Arrow keys to move within and between text fields.
- Use your mouse scroll wheel to navigate through menus.
- Adjust the volume level on your phone by holding Alt + Up arrow key or Alt + Down arrow key.

Note: When you use PDC, you cannot enter information in phone fields that don't have a flashing cursor, and you cannot place calls using the New Call soft key.

Your keyboard function keys are also mapped to specific phone keys and soft keys, as outlined in the following tables. The key mappings vary by phone model.

To use the Function and Alt key mappings, your cursor must be on the phone's display screen.

Function and Alt Key Mappings for VVX Phones

| Function Key | Phone Key | Alt Key | Phone Key |
|--------------|---|---------|---|
| F1 | First soft key from the left on your phone's current screen | Alt+F1 | N/A |
| F2 | Second soft key from the left on your phone's current screen | Alt+F2 | Redial |
| F3 | Third soft key from the left on your phone's current screen | Alt+F3 | Transfer |
| F4 | Fourth soft key from the left on your phone's current screen | Alt+F4 | Conference |
| F6 |  | Alt+F6 | Do Not Disturb |
| F7 | Directories menu | Alt+F7 |  |
| F8 | Messages menu | Alt+F8 | New Call soft key |
| F9 | Talk soft key (if PTT is enabled) | Alt+F9 | End Call soft key |
| F10 | ACD Sign In (if enabled) | Alt+F10 | Settings. |
| F11 | Applications | Alt+F11 |  |
| F12 |  | Alt+F12 | ACD Sign Out (if enabled) |

Enter Text in a Different Language

You can also enter text in different languages onto your phone using your keyboard.

Note: The PDC does not allow you to type Chinese characters into fields on your phone using the PinYin character entry method on your computer keyboard. Instead, copy and paste these Chinese characters from a computer document into the applicable phone fields using clipboard functions.

Procedure

1. On your computer, click **Start > Control Panel > Region and Language > Keyboard and Language > Change keyboards**.
2. Choose a computer keyboard language, as shown next.

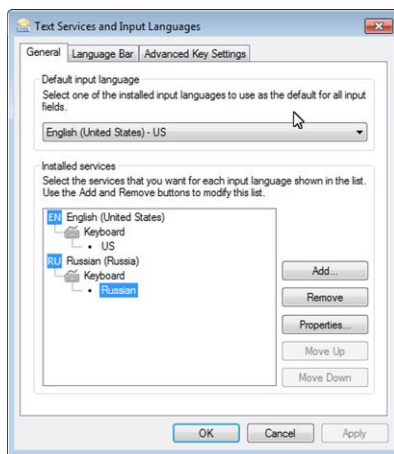

3. Move your cursor onto your phone's display screen.
The PDC program changes your keyboard language when you move your cursor onto your phone's screen.
4. On the phone, enter text in your chosen language.
The following graphic shows Russian characters entered on a VVX phone.

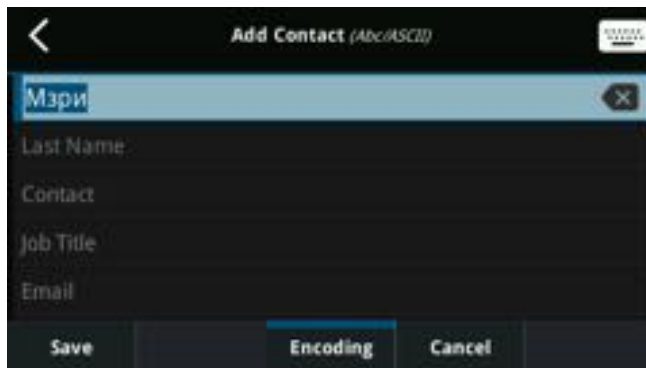

Tip: To change your keyboard language back to the original, press the keyboard shortcut **Left Alt + Left Shift** to toggle your keyboard language.

Connecting a Netgear Wi-Fi Adapter to Your Phone

A Wi-Fi adapter can connect any device with an Ethernet port to your existing wireless network. Use a Wi-Fi adapter with a VVX phone to wirelessly connect your VVX phone to your existing wireless network environment.

Connect the Wi-Fi Adapter

This section takes you through the steps to connect a VVX phone to a Wi-Fi adapter. The NETGEAR WNCE2001 is supported by Polycom and is used as the Wi-Fi adapter in the procedure.

Note: Depending on the peripheral devices you have attached to with VVX phone, the phone may not have enough power for the Wi-Fi adapter through the USB port. Therefore, Polycom recommends you use the external power supply that comes with the adapter. This is also a requirement when using a phone without a USB port.

Procedure

1. Disconnect any wireless connection to the router and/or remove the Ethernet cable currently connected to the computer.

You can restore the connection after the adapter installation is complete.

2. Connect the adapter to your computer using the Ethernet cable and USB cable.

If your computer does not have a USB port, you can use the power adapter that comes with the Wi-Fi adapter for power.



3. Wait until both the Power and LAN LEDs on the Wi-Fi adapter are solid green.
4. Make sure the computer gets the IP address.
5. Open your browser.

The NETGEAR WNCE2001 Wi-Fi adapter setup page is displayed automatically. Refer to the [NETGEAR WNCE2001 User Guide](#) if you open your browser and do not see the WNCE2001 Wi-Fi Adapter set up page.
6. Follow the instructions on the setup page.
7. After completing the setup, disconnect the Ethernet and USB cables from your computer.

8. Connect the Ethernet and USB cables on the WNCE2001 to the VVX phone.

If your VVX phone doesn't have a USB port or the USB port is disabled, you can use the power adapter that comes with the Wi-Fi adapter to power the unit.



Note: Wi-Fi Protected Setup (WPS) is a simple and secured way to connect a device to an existing network. If you have a NETGEAR router, this feature is called Push 'N' Connect. Look for the  symbol on the router to make sure the NETGEAR router supports WPS. For non-NETGEAR routers, refer to the user manual to determine if the router supports WPS.

Connecting Polycom VVX Expansion Modules to Your Phone

The Polycom VVX Expansion Modules, with a LCD color display, are consoles you can connect to VVX business media phones to add additional lines. VVX Expansion Modules enable you to handle large call volumes on a daily basis and expand the functions of your phone.

VVX 201 phones do not support VVX Expansion Modules. Check with your system administrator to find out if your phone is set up to support VVX Expansion Modules.

Note: The VVX Expansion Modules are not supported on VVX phones running UC Software 5.0.x. The expansion modules are supported only on VVX phones running UC Software 4.1.6, 4.1.7, and 5.1.x and later.

Related Links

[Place a Call from a VVX Expansion Module](#) on page 39

[Answer a Call from a VVX Expansion Module](#) on page 42

VVX Color Expansion Module Hardware Features

The following features are available on the VVX Color Expansion Modules:

- VVX Color Expansion Modules feature an easy-to-navigate 480x272 LCD display.
- Each color expansion module provides you with 28 line keys and three display pages, supporting a total of 84 lines that you can set up as registrations, favorites, or Microsoft Skype for Business presence contacts.
- You can connect up to three color expansion modules to your phone to support an additional 252 line keys per phone.

The following figure illustrates the features, components, and keys available on the VVX Color Expansion Modules. The table lists each numbered feature shown in this figure.

VVX Color Expansion Module features

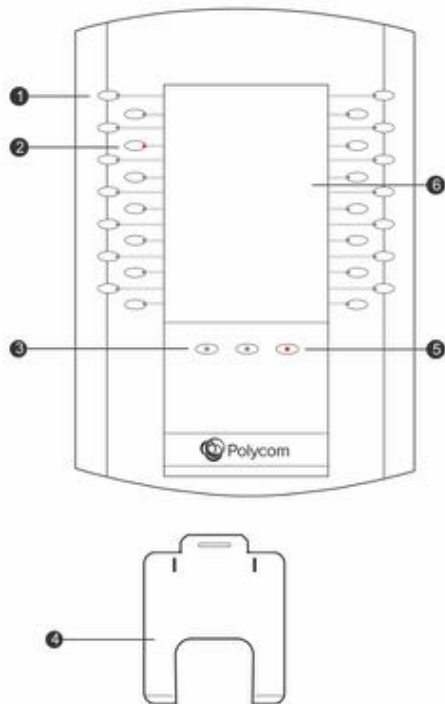

VVX Color Expansion Module Hardware Feature Descriptions

| Reference Number | Feature | Feature Description |
|------------------|----------------|--|
| 1 | Line Key | Selects available line key contacts, functions, and assignments. |
| 2 | LED Indicators | Indicates a line or busy lamp field contact's status. The following lists the LED Indicator behaviors shown on the expansion modules: <ul style="list-style-type: none"> • <i>Solid Green</i> Indicates an active call in progress. • <i>Fast-Flashing Green</i> Indicates an incoming call. • <i>Flashing Green</i> Indicates the remote party placed the call on hold. • <i>Solid Red</i> Indicates the phone of a monitored busy lamp field contact is placing a call or is in a call. • <i>Flashing Red</i> Indicates a held call. • <i>Flashing Green and Red</i> Indicates the phone of a monitored busy lamp field contact is on an active call or is receiving an incoming call. |
| 3 | Page Keys | Navigates between pages on the expansion module. |
| 4 | Base Stand | Hooks into the back of the expansion module to stand up the display. |

| Reference Number | Feature | Feature Description |
|------------------|---------------------|--|
| 5 | LED Page Indicators | <p>Indicates a page's status.</p> <ul style="list-style-type: none"> • <i>Fast-Flashing Green</i> Indicates an incoming call on a page not currently displayed. Press the page key with the fast-flashing green LED indicator to view the contact with an incoming call. • <i>Slow-Flashing Green</i> Indicates a monitored busy lamp field contact on a page not currently displayed is receiving an incoming call. • <i>Solid Red</i> Indicates the current page displayed. |
| 6 | Color Display | Displays line numbers, Microsoft Skype for Business presence contacts, and favorites. |

Connect VVX Expansion Modules

VVX Expansion Modules are powered and signaled by VVX phones and require minimal setup. After you connect an expansion module to a VVX phone, the module is automatically configured to work with the phone.

For more information on setting up VVX Expansion Modules, see the [Quick Start Guide for Polycom_VVX Expansion Modules](#).

Procedure

1. Connect an auxiliary cable from the **AUX** port on the phone to the **AUX 1** port on the expansion module.

The LED lights on the module's line keys flash red and green as the module starts up. The VVX Color Expansion Modules take approximately 20 seconds to power up.

Connect Additional Expansion Modules

After the first module is on, you can connect up to two additional modules to your VVX phone.

Procedure

1. Connect an auxiliary cable from the **AUX 2** port on the first module connected to the phone to the **AUX 1** port on the second module.
2. Connect an auxiliary cable from the **AUX 2** port on the second module to the **AUX 1** port on the third module.

The LED lights on the line keys light up for each connected module as the expansion modules start up.

Assigning Contacts and Favorites to VVX Expansion Modules

The default view on your phone screen, which is the Lines screen, displays line registrations, Skype for Business contacts, and favorites. Each function occupies a display space on the Lines screen. VVX phones support a maximum number of display spaces, which are listed in the following table. When you reach the maximum number of display spaces on your phone, the next function you add is assigned to the first available line key on your expansion module.

Maximum Number of VVX Phone Display Spaces

| Supported Phone Model | Maximum Display Spaces Supported |
|-----------------------|----------------------------------|
| VVX 300 series | 6 |
| VVX 400 series | 12 |
| VVX 500 series | 12 |
| VVX 600 series | 16 |

Note: After you fill all the display spaces on your phone and assign functions to all the lines on your expansion module, you can find additional favorites or Skype for Business contacts in the Contact Directory.

Assign Favorites to VVX Expansion Modules

You can assign favorites to line keys on VVX Expansion Modules and automatically call contacts using the line keys on the expansion modules. When you assign favorites on your phone, favorites are assigned to the next available line key on the expansion module regardless of the index number. You can reorder your favorites once they are created by changing the value of their index number.

Procedure

1. Press and hold an available line key on your expansion module.
2. From the **Add Contact** screen, enter the contact's information, including a unique favorite index, and select **Save**.

VVX 500/501 and 600/601 phones automatically assign a favorite index. The favorite is assigned to the next available line on your expansion module and not necessarily the line corresponding to the line key you pressed to assign the favorite.

Related Links

[Add Favorites](#) on page 82

Assign Skype for Business Contacts to VVX Expansion Modules

When your phone is registered with Microsoft Skype for Business Server, you can assign Skype for Business contacts to line keys on your VVX Color Expansion Module. You can choose to assign contacts to a line key from your Contacts list, or from searching for a contact in the Skype Directory.

When you assign Skype for Business contacts to a line key on the expansion module, you can quickly call contacts by pressing the corresponding line key. You can also monitor your Skype for Business contacts' presence status and monitor Boss lines you are assigned as a delegate.

Procedure

1. Navigate to **Settings >Basic > Line Key Customization**.
2. Select **Expansion Module Line Keys**.
3. Press a line key on the expansion module and select **Assign**.

4. Choose one of the following to assign your contact to the line key:
 - Select **Skype Search** and enter your search criteria to find a contact in the Skype Directory.
 - Select **Contacts** to choose a contact from the Contacts list.

5. Select your contact and press **Assign**.

The contact is assigned to the selected line key.

Related Links

[Assign Skype for Business Contacts to Line Keys](#) on page 85

[Enable Line Key Customization](#) on page 110

Identify Line Key Assignments

You can identify which registrations, Skype for Business contacts, and favorites are assigned to each line key on your expansion module in the Status menu on your VVX phone.

Procedure

1. Navigate to **Settings >Status > Line Key Information**.

2. Press a line key on the expansion module.

The assignment and line number for the line key you pressed is displayed on your phone's screen.

3. Press the line key twice to return to the previous menu, or select **Back**.

Navigate VVX Color Expansion Module Paging

The VVX Color Expansion Modules display three pages of line information on the LCD screen for each module connected to a VVX phone. Each page of the expansion module contains 28 registrations, Skype for Business contacts, or favorites assigned to line keys.

Procedure

1. Press a Page key beneath the screen on the VVX Color Expansion Module.

Smart Paging

The Smart Paging feature arranges line key assignments and distributes pages on the VVX Color Expansion Modules based on the number of expansion modules connected to a VVX phone. Smart Paging is automatically enabled for VVX Color Expansion Modules connected to VVX phones with UC Software 5.1.0 or later.

Smart Paging does not affect how pages are ordered on VVX Expansion Modules with paper displays.

Note: If you assigned functions to line keys using the Flexible Line Key feature, the line key assignments display on the designated line key on the expansion module and are not affected by Smart Paging.

When Smart Paging is enabled, the pages on the VVX Color Expansion Module are distributed across all connected expansion modules. This feature is described and shown in the following scenarios:

- If you only have one expansion module connected to your VVX phone, the pages are ordered sequentially on the module, as shown in the next figure. Press the first, second, or third **Page** key to view the corresponding pages.



- If you have two expansion modules connected to your VVX phone, the pages are ordered non-sequentially. As shown in the next figure, the pages display on the two expansion modules in the following order:
 - Pages 1, 3, and 4 display on the first expansion module.
 - Pages 2, 5, and 6 display on the second expansion module.

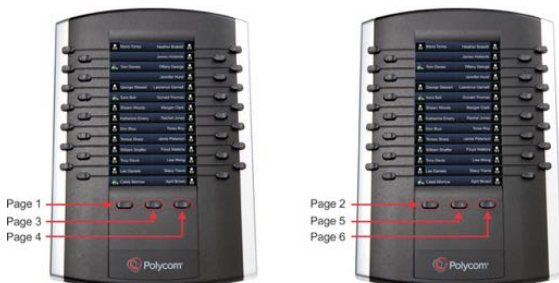

- If you have three expansion modules connected to your VVX phone, the pages are ordered non-sequentially. As shown in the next figure, the pages display on the three expansion modules in the following order:
 - Pages 1, 4, and 5 display on the first expansion module.
 - Pages 2, 6, and 7 display on the second expansion module.
 - Pages 3, 8, and 9 display on the third expansion module.



Alternate Paging

When Smart Paging is disabled, the ordering of the pages on the expansion modules is not affected by the number of expansion modules connected to your VVX phone. With Alternate Paging, the expansion modules' pages are ordered sequentially from 1 to 9. The next figure shows Alternate Paging on three expansion modules.

Alternate Paging on VVX Color Expansion Modules



Changing the Backlight Intensity on VVX Expansion Modules

When you change the backlight intensity settings on your VVX phone, the backlight on your VVX Color Expansion Module connected to your phone automatically changes to match the new settings.

Related Links

[Backlight Intensity and Timeout](#) on page 105

Connecting to Skype for Business on Your Phone using Better Together over Ethernet

Better Together over Ethernet (BToE) with Skype for Business on VVX phones enables you to communicate with Skype for Business contacts using your Skype for Business client while providing you with quality audio through your VVX phone.

BToE also enables you to control Skype for Business audio and video call activity from your VVX phone and your computer using your Skype for Business client. You can also use BToE to sign in to your phone using your Skype for Business credentials.

In order to use BToE, you need to download and install the Polycom BToE Connector application.

Installing the Polycom Better Together over Ethernet Connector

The Polycom BToE Connector enables you to use the BToE feature on your VVX phone when it's connected to a Microsoft® Windows® computer. You must download, install, and start the Polycom BToE Connector application before enabling and pairing BToE on your phone and computer.

You can install the Polycom BToE Connector application on the following operating systems:

- Windows 7
- Windows 8
- Windows 8.1
- Windows 10

Download the Polycom BToE Connector

Before you can start using BToE, you need to download the BToE Connector application, version 3.5.0 or later, from [Polycom Voice Support](#).

Procedure

1. On the support site, click **Polycom Better Together over Ethernet Connector Application**, version 3.5.0 or later.
A screen with Polycom's user terms and conditions display.
2. Agree to Polycom's user terms and conditions, and click **Submit**.

Install the Polycom BToE Connector

After you have downloaded the Polycom BToE Connector installer, you can install the application on your computer.

Procedure

1. Unzip the downloaded file and click the **Polycom BToE Connector.msi** file.
The setup dialog box is displayed.
2. Click **Agree and Install** to continue.
3. Choose an installation folder and click **Install**.
By default, the Polycom BToE Connector application installs in the `C:\Program Files (x86)\Polycom\Polycom BToE Connector\` folder.
A User Account Control dialog box is displayed.
4. Ensure that the dialog box lists **Polycom Inc.** as the verified publisher and click **Yes**.
If Polycom Inc. is not listed as the publisher, click **No** and download the application again from the [Polycom Voice Support](#) site.
A Windows Security dialog box is displayed.
5. Ensure that the dialog box lists **Polycom Inc.** as the publisher and click **Install**.
6. Select the **Always trust software from Polycom Inc.** check box if you want your computer to automatically allow future software downloads from Polycom.
A dialog box showing the Polycom BToE Connector installation's progress is displayed.
7. After the software has finished installing, click **Finish**.
The **View Readme file** and **Launch Polycom BToE Connector** options are selected. You can choose to uncheck these options before clicking **Finish**.
If you do not uncheck the **Launch Polycom BToE Connector** option, the Polycom BToE Connector application starts on your computer and the icon  is displayed in the notification area of your system tray, as shown next. If you uncheck the option, the desktop icon is displayed on your desktop, and the application does not start.



Start the Polycom BToE Connector

If you do not choose to open the Polycom BToE Connector Application during the installation process, you must start the application before connecting your phone to your computer.

Procedure

1. Click the Polycom BToE Connector desktop icon  on your computer, or click **Start > All Programs > Polycom > Polycom BToE Connector**.

Disable Auto-Start for the Polycom BToE Connector

After you start the application the first time, the Polycom BToE Connector automatically launches when you start your computer. If you do not want the application to automatically start on your computer, you can disable the auto-start feature.

Procedure

1. On your computer, open the **Start** menu and type **Run** in the search field.
2. Click **Run**, type `msconfig` in the text field, and click **OK**.
3. In the **System Configuration** dialog box, click the **Startup** tab.
4. Find **Polycom BToE Connector**, and uncheck the check box, as shown next.

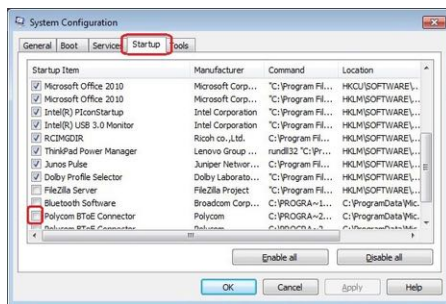

5. Click **OK > Exit without restart**.

Pairing Your Phone with Your Computer

By default, BToE is enabled on your phone when you sign into the phone with your Skype for Business user credentials. When BToE is enabled, the BToE icon  is displayed in the status bar on your phone.



Before you can begin using BToE, you must pair your Polycom phone with your computer. By default, your phone is set to pair with your computer automatically when Better Together over Ethernet is enabled, and you connect your phone to your computer over Ethernet. You can choose to manually pair your phone with your computer using the BToE Connector application and a pairing code generated by your phone.

Automatically Pair Your Phone with Your Computer using BToE

By default, your phone is set to automatically pair with your computer when you connect your phone to your computer over Ethernet.

When your phone is paired with the Skype for Business client on your computer, the message “Successfully paired” is displayed on your phone, and the BToE Mode icon  displays in the system tray on your computer.

Procedure

1. On your phone, navigate to **Settings > Features > BToE PC Pairing**.
2. Select **Pairing Mode** then select **Auto**.
3. Connect an Ethernet cable from your computer to the PC port on your phone.
The message “Successfully Paired” is displayed on the phone, and, if you are not signed into Skype for Business on your phone, a dialog box is displayed on your computer asking for your Skype for Business login credentials.
4. If the dialog box does not display on your computer, select **Sign In** on your phone and choose **User Credentials** or **Paired Client**.
5. Enter your login credentials in the dialog box.
The message “Better Together Activated” is displayed on your phone, the BToE icon  is displayed on the status bar, and the Paired BToE icon  is displayed in the system tray on your computer.



Polycom VVX Phone is displayed in your list of audio devices in your Skype for Business client. When the same user account is signed into the phone and the Skype for Business client, your computer and phone are paired, and BToE is activated. However, when the phone and Skype for Business client are signed into with different user accounts (for example, when you connect your computer to a shared phone), the computer and phone are paired, but BToE is not activated.

Manually Pair Your Phone with Your Computer using BToE

You can use a pairing code generated by your phone to manually pair your computer with any Skype for Business-enabled phone on your company's network. When you set your phone to manually pair with your computer, your phone generates a six-digit pairing code, and you must enter that code into the Polycom BToE Connector application.

Note: You must have the Polycom BToE Connector application, version 3.4.0 or later, to use manual pairing.

Procedure

1. On your phone, navigate to **Settings > Features > BToE PC Pairing**.
2. Select **Pairing Mode** then select **Manual**.
3. Connect an Ethernet cable from your computer to the PC port on your phone.
A six-digit pairing code displays. For example, 459368.
4. On your computer, click the Polycom BToE Connector desktop icon  to start the application.
5. Right-click the application icon  then click **Pair with Phone**.

- Enter the six-digit pairing code shown on the phone into the notification on your computer, as shown, then click **Pair**.

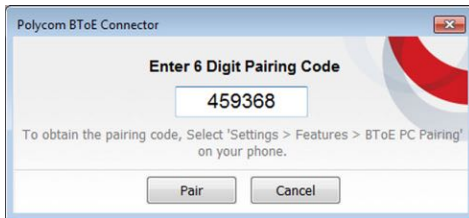

The application attempts to pair with the phone, and the following dialog displays.

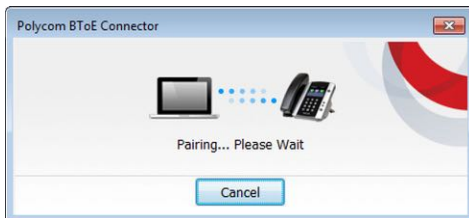

If the pair code was entered correctly, a dialog box indicating that the computer is successfully paired with the phone displays on your computer, as shown next. If the phone is registered before pairing, the following dialog box displays the phone registration instead of the IP and MAC addresses.



- If the phone is not registered, enter your login credentials into the dialog displayed on your computer.

The message “Better Together Activated” is displayed on your phone and the BToE icon  is displayed on the status bar.

When your phone is paired with the Skype for Business client on your computer, the message “Successfully paired” is displayed on your phone, and the BToE Mode icon  displays in the system tray on your computer.

Set Your Phone as Your Primary Audio Device

Before you begin using the BToE feature, you need to ensure that your Polycom VVX phone is set as your primary audio device in your Skype for Business client on your computer.

Procedure

1. In your Skype for Business client, click the audio device icon  and select **Polycom VVX Phone** as your primary device.

Use Your Phone as Your Primary Audio Device for Your Computer

In addition to the audio from Skype for Business calls playing on your phone, you can also have the audio from media, such as music or web videos, play on your VVX phone by setting your phone as your primary audio device for your computer.

Procedure

1. On your computer, click **Start > Control Panel**.
2. In the **Control Panel**, click **Hardware and Sound > Sound**.
3. Click **Polycom VVX Phone** and click **Set Default**.
4. Click **OK**.

Any audio from music or videos plays on your VVX phone, and the PC Audio screen is displayed, as shown next.



Use BToE to Open the Web Configuration Utility

When your phone is paired with your computer, you can launch the Web Configuration Utility from the Polycom BToE Connector application.

You can use the Web Configuration Utility to update or change user features for your phone.

Procedure

1. On your computer, right-click the BToE application icon  in the system tray then click **Launch VVX Web UI**.

Using BToE to Lock and Unlock Your Phone

When your phone is paired with your computer, you can lock and unlock your phone automatically when you lock or unlock your computer.

With the BToE Connector, version 3.5.0 or later, when you lock your computer, your phone locks within 10 seconds after your computer, or a designated time set by your administrator, if your phone is not in use. When you unlock your computer, your phone unlocks immediately after your computer.

Using BToE to Manage Calls on Your Phone and Skype for Business Client

After your VVX phone is paired with your computer, you can manage audio and video calls with your Skype for Business contacts on your phone and in the Skype for Business client on your computer.

Using any registered VVX phone as your primary audio device, you can place and answer audio and video calls, hold and resume audio calls, and pause and resume video calls on your VVX phone. You can use BToE with any VVX phone for all Skype for Business calls even if you are not signed into your Skype for Business account on the phone. When you connect a VVX phone that is registered to another user to your computer, the phone acts as a speakerphone for all audio and video calls initiated in the Skype for Business client on your computer.

You can only have a video call between you and one other person when BToE is enabled. Calls with three or more people are audio-only.

Note: If you want to route audio from media that uses the computer's speakers, such as from web videos or media players, you must manually change the computer's default audio speaker device to use Polycom VVX Phone.

Answer BToE Calls

When you are signed into the Skype for Business client and the connected phone with the same account, the way you answer calls is different than if the Skype for Business client and the connected phone are signed in with different accounts.

Procedure

1. Do one of the following:
 - If signed in with the same user accounts, press the **Answer** soft key on your phone or click **Answer** in the Skype for Business client.
 - If signed in with different user accounts and the incoming call is for the account signed into Skype for Business, click **Answer** in the Skype for Business client.

The call is displayed on the VVX phone and Skype for Business client. On the phone, the PC audio icon  is displayed next to the Skype for Business call, and the audio for the call is played through the phone's speakerphone.

- If signed in with different user accounts and the incoming call is for the account signed into the phone, press the **Answer** soft key on the phone.

The call is displayed on the phone only.

Place BToE Calls

You can place calls to Skype for Business contacts in the Skype for Business client and on your phone.

Procedure

1. Choose a contact and select **Call**.

Pause and Resume BToE Calls

You can pause active audio and video Skype for Business calls on your phone when you are signed into different user accounts on your phone and the Skype for Business client. You can also pause video calls when you are signed into the same user account on the phone and in the client. However, when you pause an audio or a video call on your phone, the call remains active in the Skype for Business client on your computer.

Procedure

1. Select **Pause** on your phone.
The audio or video call is paused on your phone, but not in the Skype for Business client on your computer.
2. Press **Resume** on your phone.

Move Call Audio between Your Phone and Computer

During an active Skype for Business call, you can move the call audio from your phone to your computer or from your computer to your phone.

Procedure

1. During an active call in the Skype for Business client, click .
2. Click **Devices** and do one of the following:
 - Click **Handset** to move the call audio from your computer to your phone.
 - Click **PC Mic and Speakers** to move the call audio from your phone to your computer.

Disable BToE on Your Phone

When you disable BToE, you can no longer use the feature on your VVX phone and Skype for Business client on your computer.

Procedure

1. Do one of the following:
 - Disconnect the Ethernet cable from the PC port on your phone.
 - Navigate to **Settings > Advanced > Administration Settings > BToE PC Pairing** and press **Disabled**.

BToE is disabled on your phone, and you can no longer use the BToE feature.

Related Links

[Uninstall the Polycom BToE Connector](#) on page 144

Stop BToE on Your Computer

When you stop the application, you can no longer use the BToE functions on your Polycom phone and computer.

Procedure

1. Right-click  in the system tray and select **Exit**.

The Polycom BToE Connector is no longer active on your computer and you cannot use the BToE feature.

Uninstall the Polycom BToE Connector

After you uninstall the Polycom BToE Connector, you can no longer use BToE.

Before uninstalling the Polycom BToE Connector, you need to disable BToE and unpair your phone and computer.

If you decide to start using the BToE feature again, you must reinstall the Polycom BToE Connector and repeat the steps for enabling and pairing your Polycom phone and computer.

Procedure

1. In the **Start** menu, select **All Programs > Polycom > Polycom BToE Connector > Uninstall Polycom BToE Connector**.

A dialog box asking if you're sure you want to uninstall this product is displayed.

2. Choose **Yes** to uninstall the Polycom BToE Connector.

A dialog box showing the progress of the application uninstall is displayed.

Related Links

[Disable BToE on Your Phone](#) on page 143

Accessibility Features

Topics:

- [Features for Hearing-Impaired Users](#)
- [Features for Mobility-Impaired Users](#)
- [Features for Vision-Impaired and Blind Users](#)

Polycom products include a number of features to accommodate any type of user. The following sections describe accessibility features for hearing, vision, or mobility-impaired users available on VVX Business Media Phone.

Features for Hearing-Impaired Users

The following table lists the accessibility features for hearing-impaired users.

Accessibility Features for Hearing-Impaired Users

| Accessibility Feature | Description |
|---------------------------------|--|
| Visual message indicators | An indicator light on the phone indicates that new messages are waiting. Icons on the screen also indicate that the phone has new messages. |
| Adjustable ring tone and volume | You can choose from a variety of ring tones for the phone. You can also change the volume of the ringer to suit your needs and choose different ring tones for contacts. |
| Adjustable call volume | If you're in a call, you can raise or lower the volume of the voice on the far end and of other sounds you hear. |
| Visual notifications | Indicators on the screen (such as flashing bars or icons) let you know when calls are incoming, outgoing, active, or held. Indicators can also indicate phone status and if certain features are activated. |
| Visual ringing | Certain VVX models have visual ringing that enables the screen to flash bright orange for incoming calls (contact your system administrator). |
| Electronic hookswitch support | If you use a headset that supports electronic hookswitch (EHS), you can use the controls on your headset to answer and end calls. In addition, you may be able to mute calls and control volume from your headset. |
| Headset Memory Mode | If you use a headset, you can set up your phone so that all calls use your headset. |

| Accessibility Feature | Description |
|---------------------------------------|---|
| Hearing Aid Compatible (HAC) handsets | All VVX handsets are Hearing Aid Compatible (HAC) and have telecoils that magnetically couple to most forms of wearable hearing aids per FCC section 508 (compliant to ADA Section 508 Recommendations: Subpart B 1194.23). |
| TTY support | phones support commercial TTY devices such as Ultratec Superprint. In addition, the phones provide acoustic coupled TTY support. |

Related Links

[Changing Audio Settings](#) on page 116

[Enable Electronic Hookswitch](#) on page 120

[Use Your Headset for All Calls](#) on page 119

[Icons and Status Indicators](#) on page 21

Features for Mobility-Impaired Users

The following table lists the accessibility features for mobility-impaired users.

Accessibility Features for Mobility-Impaired Users

| Accessibility Feature | Description |
|--|---|
| Auto-answer feature | VVX Business Media Phone can auto-answer calls so you don't have to choose an option to answer a call. |
| Dedicated headset jack that enables the auto-answer function | If you use a headset, you can set up your phone so that all calls use your headset. |
| Touchscreen | With a large touchscreen, you can select, swipe, and press to perform phone functions and activate features. |
| Large keys | VVX phones have large keys that are well-spaced on the phone console. |
| Built-in speakerphone | A built-in speakerphone allows you to use the phone without having to use a handset or headset. |
| Adjustable phone stand | VVX phones have stands that you can adjust to various angles so your phone sits at a comfortable angle on your desktop (see your phone's <i>Quick Start Guide</i> on Polycom Voice Support web page). |
| Polycom Desktop Connector application | You can use your computer's mouse and keyboard to enter information and navigate screens on your VVX phone. |

Related Links

[Answer Calls Automatically](#) on page 41

[Controlling Your Phone with Polycom Desktop Connector](#) on page 123

[Use Your Headset for All Calls](#) on page 119

[Controlling Calls with Electronic Hookswitch](#) on page 121

Features for Vision-Impaired and Blind Users

The following table lists the accessibility features for visually-impaired and blind users.

Accessibility Features for Vision-Impaired and Blind Users

| Accessibility Feature | Description |
|--|--|
| Adjustable backlight settings | You can change the brightness of the screen by adjusting backlight intensity settings. |
| Auto-answer feature | A VVX Business Media Phone can auto-answer calls so you don't have to choose an option to answer a call. |
| Tactile "5" key with raised bumps | The "5" key has two bumps that let you easily discern the position of other keys on the keypad. |
| Large keys | Large keys on the phone console enable you to easily access phone features and functions. |
| Physical line keys | VVX 300 series and 400 series phones have physical line keys that you can press to answer and end calls. |
| Physical feature keys | Many features on VVX phones are accessible by pressing feature keys on the phone console. |
| Tactile-discernible number, feature, and navigation keys | Keys on the phone console are easily discernible by their size and shape. |
| Illuminated feature keys | Many feature keys are illuminated when activated, so you're easily alerted when a feature is enabled. |

Related Links

[Backlight Intensity and Timeout](#) on page 105

Maintaining VVX Business Media Phone

Topics:

- [Investigate Warnings](#)
- [Remove Warnings](#)
- [Restart VVX Business Media Phone](#)
- [Update the Configuration for VVX Business Media Phone](#)
- [Test the Hardware](#)
- [Clean the Touchscreen](#)
- [View Software Details](#)
- [Updating Your Skype for Business Phone Software](#)

When the phone is not operating properly, you can investigate or troubleshoot issues along with any other tasks your administrator may ask you to perform.

Investigate Warnings

When a phone is unable to perform certain tasks, a Warning icon  displays in the status bar.

The warning icon lets you know that your phone has one or more important issues. You can view details about the issues from the Warnings screen.

If you have a VVX 600/601, the icon has a counter indicating the number of warning messages you have, and you can tap the icon to view the messages.

Procedure

1. Navigate to **Settings > Status > Diagnostics**.
2. Select **Warnings**.

The **Warnings** screen is displayed listing any issues.

Remove Warnings

After you view phone warnings, you can temporarily remove the Warning icon from the status bar. However, the warning still displays in the Warnings list until the issue is fixed. The Warning icon is displayed each time your phone has a warning that you haven't viewed.

Procedure

1. In the **Warnings** screen, select **Clear Icon** to remove the Warning icon from the status bar.

Restart VVX Business Media Phone

Your system administrator may ask you to restart the phone if it malfunctions or to assist in troubleshooting.

Caution: Before you restart the phone, contact your system administrator. If the phone is malfunctioning, you may be able to restore normal operation without restarting it. In addition, your administrator may want to troubleshoot the phone before you restart it. You do not need to restart the phone to update its configuration.

Procedure

1. Navigate to **Settings > Basic**.

2. Select **Restart Phone**.

A confirmation message is displayed.

3. Select **Yes**.

The restart process begins, and the process ends when the Home screen is displayed.

Related Links

[Update the Configuration for VVX Business Media Phone](#) on page 149

Update the Configuration for VVX Business Media Phone

Your system administrator may ask you to update the configuration for your phone to apply any changes to system settings, which you can do without restarting it.

Procedure

1. Navigate to **Settings > Basic**.

2. Select **Update Configuration**.

A confirmation message is displayed.

3. Select **Yes**.

The configuration is updated. The phone may restart, depending on which settings have changed.

Related Links

[Restart VVX Business Media Phone](#) on page 149

Test the Hardware

Your system administrator may ask you to access a diagnostics menu on the phone to test its hardware. You can test the touchscreen, microphones, speaker, handset, third-party headset (if connected), keypad mappings, and LEDs. Contact your system administrator for instructions on how to perform these tests.

Procedure

1. Navigate to **Settings > Status > Diagnostics**.
2. Select **Test Hardware** and select one of the following:
 - **Audio Diagnostics**
 - **Display Diagnostics**
 - **Touch Screen Diagnostics**
 - **Brightness Diagnostics**
 - **LED Diagnostics**
 - **Keypad Diagnostics**

Clean the Touchscreen

The touchscreen on VVX 500/501 and 600/601 phones requires minor maintenance, but you may need to clean the touchscreen periodically. Use a clean, dry, microfiber cloth—the kind you would use to clean glass surfaces—to wipe the touchscreen. Do not use chemicals to clean the touchscreen.

Before you clean the screen, disable it so you don't activate phone functions while you wipe the touchscreen.

Procedure

1. Navigate to **Settings > Basic**.
2. Select **Screen Clean**.
3. Wipe the screen with a clean, dry, microfiber cloth.
4. Press any key on the phone dial pad to enable the touchscreen again.

Note: If the touchscreen is dirty after cleaning, dampen a soft, lint-free cloth with an isopropyl alcohol and water solution of 50:50 then wipe the screen with the cloth. Always use the dampened cloth to apply the solution; never apply the solution directly because it could seep inside the screen or stain the system. In addition, do not use chemicals to clean the touchscreen.

View Software Details

You can view the details for the software version on your phone, the latest software update available for your phone, and the status of the latest update.

Procedure

1. Navigate to **Settings > Status > Software Update**.

Updating Your Skype for Business Phone Software

When you are signed into Skype for Business on your phone, you can update your phone with the latest UC Software from the Skype for Business server and view information for the software update.

View Software Update Information

You can view information about the software update before you update your phone.

Procedure

1. When prompted to update software, press **Details**.

Update Your Skype for Business Phone Software

When a software update is available, a notification is displayed on your phone.

Procedure

1. When prompted to update software, press **Reboot** to restart the phone and get the latest update.

Update Skype for Business Software Later

If you do not want to update your phone software when prompted, you can choose to cancel the prompt and update the software at a later time. You can press the Dev Updt soft key at any time to update the phone's software.

If your phone is inactive for a long period of time, the phone automatically reboots and updates the phone software.

Procedure

1. When prompted to update software, press **Cancel**.
The **Dev Updt** soft key is displayed.
2. Press the **Dev Updt** soft key when you're ready to update your phone's software.

Troubleshooting

Topics:

- [Speakerphone](#)
- [USB Port](#)
- [Check the Status of the Calendar](#)
- [Polycom Desktop Connector](#)
- [Troubleshoot Audio and Echo Issues](#)
- [Bluetooth Headset](#)
- [Recording Issues and Solutions](#)
- [Better Together over Ethernet](#)
- [Login Credentials](#)

This section lists potential issues, problems, and common difficulties and possible solutions to guide you towards resolving those issues.

Speakerphone

If your speakerphone doesn't work, your system administrator may have disabled it. If this is the case, a message is displayed informing you that Handsfree is disabled after you press the speakerphone key. In this case, use the handset or a headset to handle calls.

USB Port

If you attach a USB device to your VVX 401/411, 500/501, or 600/601 phone, and the phone does not detect the attached USB device, your system administrator may have disabled the USB port on your phone. In this case, you cannot attach a USB flash drive to your phone to use the following features:

- Call recording
- Picture frame
- USB headset
- USB charging device on the VVX 600/601

Contact your system administrator for help on enabling the USB port on your phone.

Check the Status of the Calendar

When you do not see the Calendar icon on the Home screen or if you are not receiving meeting reminders, it is possible that phone is not connected to the Microsoft Exchange Server.

Procedure

1. Navigate to **Settings** > **Features** > **Calendar**.
2. From the **Calendar** screen, select **Connect**.

Related Links

[Using the Calendar](#) on page 99

[Open the Calendar](#) on page 99

Polycom Desktop Connector

If you encounter any issues using the Polycom Desktop Connector (PDC), see the following table for possible solutions to common problems.

Common PDC Problems and Solutions

| Issue | Corrective Action |
|--|---|
| The computer and phone cannot establish a connection. | Verify the Polycom Desktop Connector settings on your phone. You may need to reboot your phone or press the Reconnect soft key. |
| I can't enter information in a phone field using my computer keyboard. | Check to see if the phone field has a flashing cursor. You can use PDC only to enter information in a phone field if the field has a flashing cursor. |
| I can't place a call. | If you're using PDC, you can't place a call using the New Call soft key. To place a call, enter the phone number and select the Dial soft key or tap  . |
| I want to change the phone that is connected to the Polycom Desktop Connector. | <p>Disable the Polycom Desktop Connector, which is already connected to your computer and is in active state on your phone.</p> <p>Setup and enable the phone you want to connect to Polycom Desktop Connector. Once your computer receives an initial communication from the newly configured phone, it asks you to confirm the connection by displaying the message "You were controlling <MACaddress1> with your computer. Do you want to change to controlling <MACaddress2>?" Click OK.</p> |

Related Links

[Controlling Your Phone with Polycom Desktop Connector](#) on page 123

Troubleshoot Audio and Echo Issues

In some cases when you are using your headset during a call, your contacts may experience audio or echo issues, such as feedback of your voice or of their own voice. If your contacts hear an echo during a call when using your headset, you need to enable echo cancellation on your phone.

Procedure

1. Navigate to **Settings >Basic > Preferences > Headset > Echo Cancellation**.
2. Select **Enabled**.

Related Links

[Use Your Headset for All Calls](#) on page 119

Bluetooth Headset

If you encounter any issues using a Bluetooth headset, see the following table for possible solutions to common problems.

Common Bluetooth Headset Issues and Solutions

| Issue | Corrective Action |
|---|---|
| The Bluetooth settings do not display on my phone | Do one of the following: <ul style="list-style-type: none"> • Check with your system administrator to see if the Bluetooth feature is enabled on your phone. • Make sure the Bluetooth Radio setting is on. |
| My headset doesn't pair automatically. | If your headset is an older model, you may need to enter a password before the headset can pair with your phone. Refer to your headset documentation for more information. |

Related Links

[Enable Bluetooth and Connect a Headset](#) on page 121

Recording Issues and Solutions

If you encounter any issues recording calls, see the following table for possible solutions to common problems.

Common Recording Issues and Solutions

| Issue | Corrective Action |
|-------|-------------------|
|-------|-------------------|

| | |
|--|---|
| The message “USB device is full. Recording canceled” is displayed when I pressed Start. | Check that there is sufficient space on the USB flash drive. |
| The recording stopped during a call. | If the USB flash drive becomes full during recording, recording stops and the message “USB device is full. Recording stopped” is displayed. Delete previous recordings to make space on the USB drive. |
| The message “USB device removed unsafely. Recording canceled” displayed when I removed my USB flash drive during a call. | Do not remove the USB flash drive while recording. If you want to remove the drive during a call, press Stop , and then remove the drive. |
| The message “Unsupported USB device attached” displayed. | Refer to <i>Feature Profile 37477: Using Headsets with Polycom Phones</i> on Polycom Support for a list of USB devices supported on Polycom phones. |

Better Together over Ethernet

Use the following solutions as a guide to resolving issues, problems, or common difficulties while installing the Polycom BToE Connector or pairing your devices.

Troubleshoot Polycom BToE Connector Installation

If the Polycom BToE Connector fails to install, download and reinstall the application from [Polycom Voice Support](#) on your computer.

If the application installation continues to fail, find the log file for the installation error and call [Polycom Technical Support](#). The technical support representative needs the log file to understand why the installation failed.

If you cannot access the log files, contact your system administrator for assistance.

Procedure

1. Open the **Start** menu and select your user name.
2. Select the folders `AppData > Local > Temp > MSI*.LOG`.

Troubleshoot Polycom BToE Connector Start Issues

If the Polycom BToE Connector successfully installs, but the application fails to start or you experience other application-related failures, uninstall the Polycom BToE Connector and reinstall the application.

If the application still does not start or you experience other related issues, find the log file showing the failed to start error and call [Polycom Technical Support](#). The technical support representative needs the log file to understand why the application failed to start.

If you cannot access the log files, contact your system administrator for assistance.

Procedure

1. Open the **Start** menu and select your user name

2. Select the folders `AppData > Local > Polycom > Polycom BToE Connector`.
3. Click the file `polycom_BTOE_log.txt`.

Troubleshoot Pairing

If you are having trouble pairing your VVX phone with your computer, make sure the Ethernet cable is plugged into the PC port on the phone.

If the Ethernet cable is connected properly and a warning message that the phone was unable to pair continues to display, ensure that Polycom BToE Connector is an allowed program in your system's firewall on your computer.

Procedure

1. Navigate to **Start > Control Panel > System and Security > Windows Firewall > Allow a program through Windows Firewall**.
2. Click **Change Settings**.
3. Search for **Polycom BToE Connector** in the list of applications and click the check boxes for **Domain, Home/Work, and Public** networks.

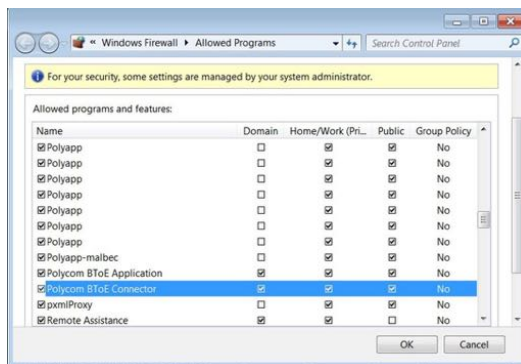

4. Click **OK**.

Login Credentials

If your phone has incorrect login credentials, or if you need to resubmit Login Credentials, one of the following messages or icons display on your phone:

- The message "Login Credentials have failed. Please update them if the information is correct" is displayed on the screen.
- A lock icon  is displayed in the status bar.
- The message "Invalid login credentials" scrolls under the time in the status bar.
- The Calendar icon that displays on the Home screen is not available.

Set Log Levels

Your system administrator uses log files to understand any issues with your phone, and may ask you to set the level for log files to reduce the amount of logs produced.

Contact your system administrator before setting a log level for your phone.

Procedure

1. Navigate to **Settings > Basic > Diagnostic Logs > Server Log Level**.
2. Choose a log level.

Send Log Files to the Skype for Business Server

You can send log files for your phone to the Skype for Business server directly from your phone.

Procedure

1. On the phone, navigate to **Settings > Basic > Diagnostic Logs > Upload Logs**.
The log files are uploaded to the server, and your system administrator can access the logs to determine any issues with your phone.

Send Log Files to the Skype for Business Server using the Web Configuration Utility

You can send log files for your phone to the Skype for Business server using from the Web Configuration Utility.

Procedure

1. Enter the IP address of your phone into a web browser. For example, enter *https://10.223.4.54*.
2. Select **User** and enter your user password.
The default user password is 123.
3. In the Web Configuration Utility, navigate to **Diagnostics > Upload Logs**.
The log files are uploaded to the server, and your system administrator can access the logs to determine any issues with your phone.